

NO. E1AH-3316

ISSUED: FEB. 2010

REVISED:

SERVICE INFORMATION

; -



**HOSHIZAKI
SELF-CONTAINED CUBER**

MODEL IM-65LE-Q

PARTS LIST

[HE]

U-0 JUL. 2009

V-0 JAN. 2010

MATERIAL ABBREVIATIONS

ALUMINUM

AL = Aluminum

COPPER

CU = Copper

PLASTIC

ABS = Acrylonitrile -butadiene - styrene
AC = Polyacetal
EVA = Ethylene vinyl acetate
PA = Polyamide = Nylon
PC = Polycarbonate
PE = Polyethylene
PES = Polyester
PETP = Polyethylene terephthalate = Tetlon
PP = Polypropylene
PS = Polystyrene
PTFE = Polytetrafluoroethylene = Teflon
PUR = Polyurethane
PVC = Polyvinyl chloride

RUBBER

VN = Vinyl Nitrile
EPDM = EP rubber
NBR = Nitrile butadiene rubber
NR = Natural rubber
NP = Neoprene
SI.R = Silicone rubber
SY.R = Synthetic rubber
EPH = Epichlorohydrin

STEEL

GS = Galvanized steel
SS = Stainless steel
PS = Plated steel
PAS = Primed steel

AUXILIARY CODE

K-0

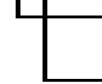

Designates the year. "K" indicates the year 2000. Years progress or regress in alphabetical order. "J" is 1999, "L" is 2001, "M" is 2002, and so on. The letters "I" and "O" were skipped.

Designates significant part changes within the same year. Base is 0 and this number advances for each change.

Example: P-1



"P" indicates 2004.

"1" indicates the first significant part change for 2004.

MARKS LOCATED UNDER THE AUXILIARY CODE

- = Part deleted.
- x = Part deleted and replaced by "o" part.
- o = New part in place of "x" part.

FASTENER ABBREVIATION LIST

ST	=	Phillips Truss Head Machine Screw
SP	=	Phillips Pan Head Machine Screw
SF	=	Phillips Flat Head Machine Screw
SS	=	Phillips Pan Head Machine Screw with Split Lock Washer
SW	=	Phillips Pan Head Machine Screw with Split Lock Washer and Flat Washer
T1	=	Phillips Truss Head Tapping Screw (Correspond to Type A)
T2	=	Phillips Truss Head Tapping Screw (Correspond to Type B)
T3	=	Phillips Truss Head Tapping Screw (Correspond to Type C)
FT	=	Phillips Truss Head Tapping Screw (Special)
BH	=	Hexagon Head Bolt
BC	=	Socket Head Cap Screw
BS	=	Hexagon Bolt with Split Washer
BW	=	Hexagon Bolt with Split Washer and Flat Washer
BF	=	Hexagon Flange Bolt
BR	=	Cross-Recessed Hexagon Head Bolt
BRW	=	Cross-Recessed Hexagon Head Bolt with Split Lock Washer and Flat Washer
WL	=	Split Lock Washer
WT	=	External Tooth Washer
WF	=	Flat Washer
WS	=	Spring Washer
NH	=	Hexagon Nut
NF	=	Hexagon Flange Nut
NC	=	Hexagon Cap Nut
NS	=	Square Nut
NW	=	Wing Nut

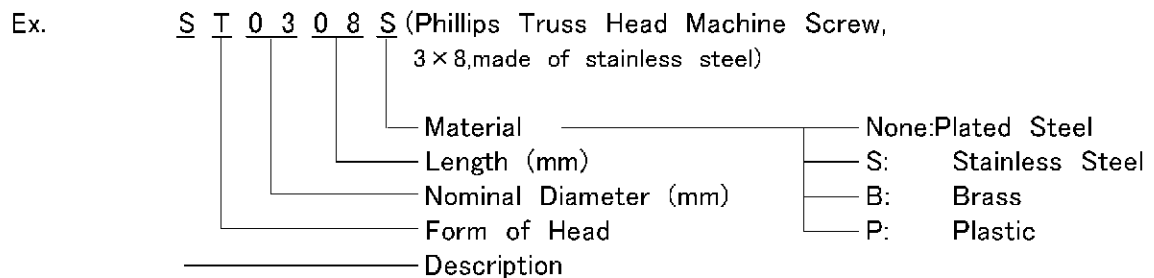

(Note) Second character is numerical except the list.
 Ex: S1,S2,B3 etc.

And abbreviations and names are shown under the illustration.

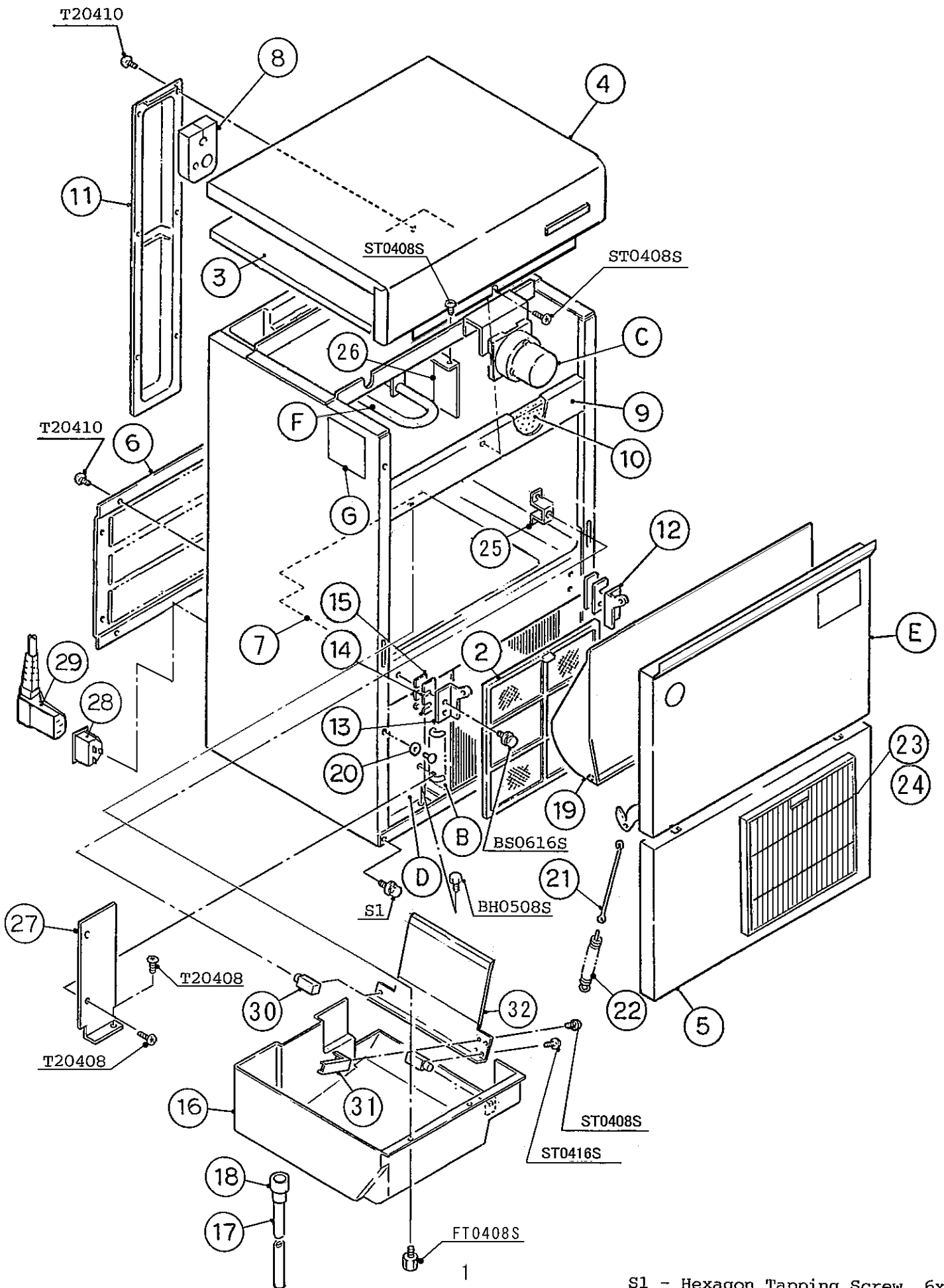

S1 - Hexagon Tapping Screw, 6x16

HE

MODEL : IM-65LE-Q		TITLE : A. ICE CUBER ASSY					
INDEX NO.	DESCRIPTION	MATERIAL OR MODEL NUMBER	PART NUMBER	REQ'D NUMBER			
				U-0 V-0			
B	REFRIGERATION UNIT		1H3340001	1			
C	ICE MAKING MECHANISM ASSY		1H4557A01	1			
D	CONTROL BOX ASSY	-	2H9677A01	1			
E	DOOR ASSY	-	3Y2903A01	1			
F	WATER CIRCUIT ASSY	-	3H9589001	1			
G	LABEL LOCATION	-	3X1504001	1			
L	ACCESSORIES		A01908-01	1			
1	UNIT FRAME	PAINTED STEEL	1H4555G01	1			
2	AIR FILTER	PP	2A2063G01	1			
3	INSULATION - TOP PANEL	PS	3Y1383G07	1			
4	FRONT PANEL (UPPER)	S.S	3X7334G05	1			
5	FRONT PANEL (LOWER)	S.S	3Y2761M01	1			
6	REAR PANEL	S.S	3H2212-01	1			
7	MAT		4H6755-01	1			
8	INSULATION	PE	4X5295-01	1			
9	FRONT FRAME	S.S	3H1678-12	1			
10	INSULATION - FRONT FRAME	PE	4H2317-03	1			
11	PIPE COVER	G.S	3H0202-03	1			
12	HINGE (RIGHT)	S.S	4H2583-01	1			
13	HINGE (LEFT)	S.S	4H2584-01	1			
14	HINGE SPACER (A)	S.S	4H0605-01	REQ'D			
15	HINGE SPACER (B)	S.S	4H0605-02	REQ'D			
16	DRAIN PAN	ABS	2H1676G01	1			
17	DRAIN TUBE	SI	4H5597-01	1			
18	DRAIN PIPE (A)	ABS	4H2585-01	1			
19	SLOPE	ABS	2H1349-02	1			
20	TAPER COLLAR	S.S	4H0171-01	2			
21	HOOK	S.S	404060-10	1			
22	SPRING	ZINC-PLATED WIRE	4H0823-01	1			
23	LOUVER(B)	PP	1A0548-01	1			
24	PUSH RETAINER	-	4A2414-01	3			
25	BRACE (B)		4X0885-01	1			
26	BRACE (D)		4H7258-01	1			
27	PLATE - FRONT	G.S	4X3941-01	1			

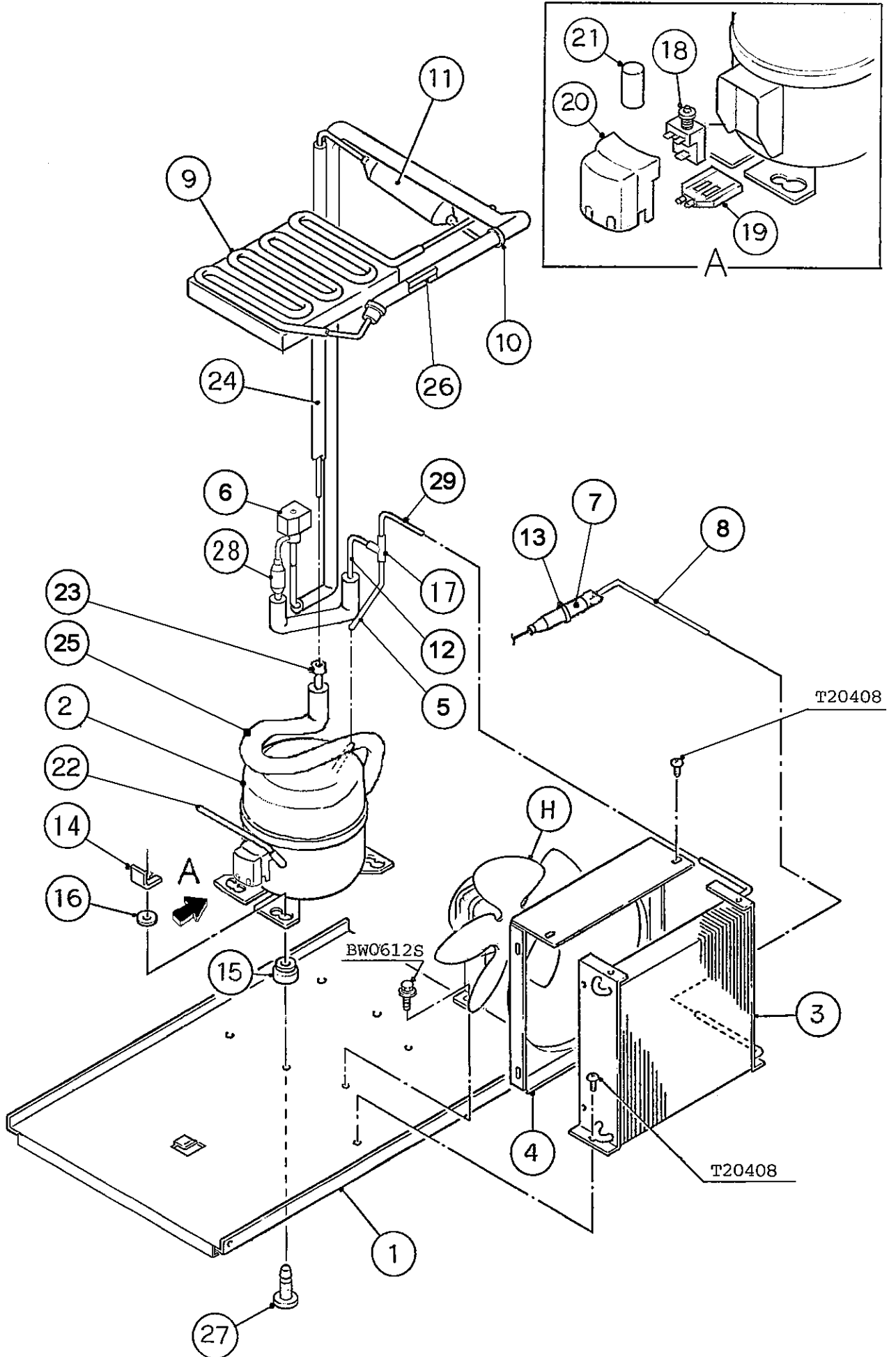

HE

MODEL : IM-65LE-Q				TITLE : B. REFRIGERATION UNIT			
INDEX NO.	DESCRIPTION	MATERIAL OR MODEL NUMBER	PART NUMBER	REQ'D NUMBER			
				U-0 V-0			
H	FAN MOTOR ASSY	(S-0950)	3H9446A01	1			
1	BASE	PAINTED STEEL	2H5704-01	1			
2	COMPRESSOR	FR11G	451196-01	1			
3	CONDENSER - AIR-COOLED	-	2H5655-01	1			
4	SHROUD	G.S	307663-01	1			
5	COPPER TUBE - HIGH SIDE	COPPER	4Y1158-01	1			
6	HOT GAS SOLENOID VALVE	AMS-24B10HD-1	418866-02	1			
7	DRIER	DY-12QHD-3	445655-04	1			
8	COPPER TUBE (A)	COPPER	4Y3360-01	1			
9	EVAPORATOR		3H4634G01	1			
10	TIE	CV-100	7920-0002	1			
11	HEAT EXCHANGER	COPPER	4X3936G01	1			
12	COPPER TUBE (A) - HOT GAS	COPPER	3X7502G01	1			
13	TIE	-	436156-01	1			
14	CLIP		452256-01	4			
15	RUBBER GROMMET	-	450897-01	4			
16	WASHER	-	450894-01	4			
17	TEE	COPPER	417394-01	1			
18	STARTING RELAY	117U6010	451197-01	1			
19	CORD RELIEF	103N1006	450899-01	1			
20	COVER	103N2010	450896-01	1			
21	STARTING CAPACITOR	117U5015	450898-01	1			
22	PROCESS TUBE (B)	COPPER	4X3379-01	1			
23	COPPER TUBE - LOW SIDE	COPPER	3X7501G01	1			
24	INSULATION TUBE (C)	15×27 L=480	3H9448-06	1			
25	INSULATION TUBE (G)	7762-1020, L=800	3X7501-02	1			
26	COPPER TUBE (B) - HOT GAS	COPPER	3X6699G01	1			
27	STEEL PIN		452255-01	4			
28	STRAINER	COPPER	451772-01	1			
29	COPPER TUBE (B) - HIGH SIDE	COPPER	4Y1096-01	1			

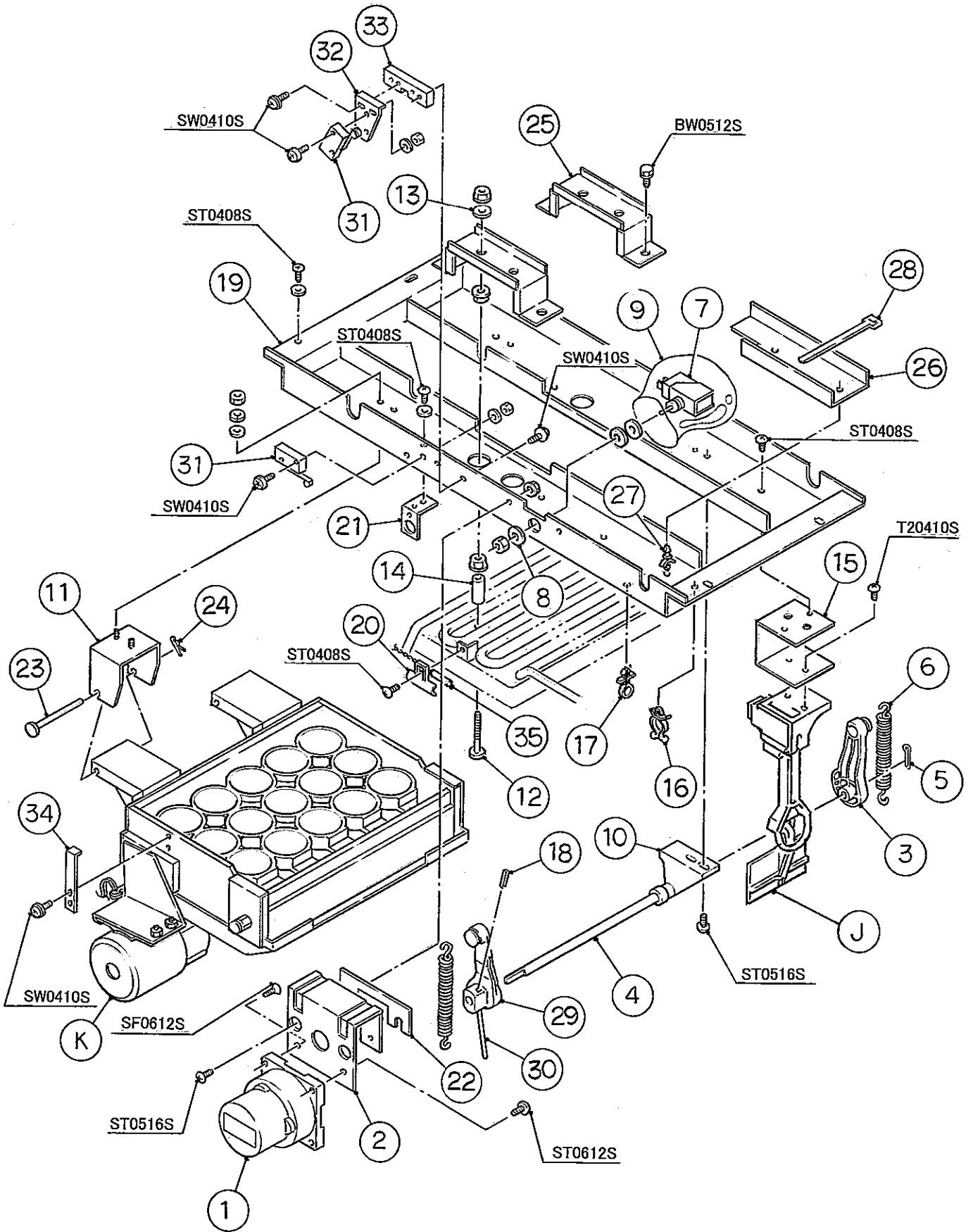

HE

MODEL : IM-65LE-Q				TITLE : C. ICE MAKING MECHANISM ASSY			
INDEX NO.	DESCRIPTION	MATERIAL OR MODEL NUMBER	PART NUMBER	REQ'D NUMBER			
				U-0 V-0			
J	BIN CONTROL SWITCH ASSY	(S-0942)	3H1537A04	1			
K	WATER PAN ASSY	(IM-65LE)	2H1940A02	1			
1	ACTUATOR MOTOR	-	457880-01	1			
2	BRACKET - ACTUATOR MOTOR	G.S	3H3740-01	1			
3	CAM (B)	AC	3H5650-01	1			
4	CAM SHAFT	AC	4Y2372G01	1			
5	SPLIT PIN	S.S, 2x12	711S-0212	1			
6	SPRING	S.S	4H0287-01	2			
7	TOGGLE SWITCH	VAT4-71	431977-01	1			
8	WASHER - TOGGLE SWITCH	S.S	406196-01	1			
9	SWITCH COVER	PE	408163-01	1			
10	CAM SHAFT HOLDER	ABS	307256-01	1			
11	BEARING PLATE		3H5926G01	2			
12	SCREW-EVAPORATOR MOUNTING		4H5788-01	4			
13	WASHER	AC	4H0777-01	4			
14	SPACER	(IM-65LE)	4H0471-01	4			
15	BRACKET-SWITCH		4H7254-01	1			
16	CLAMP	No. 2674	427902-02	1			
17	HOLDER	575	428644-02	1			
18	SPRING PIN	S.S, 3x12	712S-0322	1			
19	MECHANISM BASE		2H1764-01	1			
20	HOLDER - THERMISTOR	PE	3H9642-01	1			
21	BRACKET - PIPE		4H5585-01	1			
22	SPACER		4H5786-01	2			
23	SHAFT (A)		4H1184-01	2			
24	SNAP PIN		715S-0006	2			
25	BRACKET - EVAPORATOR		3H5000-01	2			
26	GUIDE - CONNECTOR	-	4H7290-01	1			
27	BOARD SUPPORT	KGLS-6S	414929-01	2			
28	TIE	CV-100	7920-0002	2			
29	CAM (A)		3H5648-01	1			
30	CHANGE LEVER (C)		406261-01	1			
31	MICROSWITCH		456432-01	2			
32	BRACKET-SWITCH		4H8245-01	1			

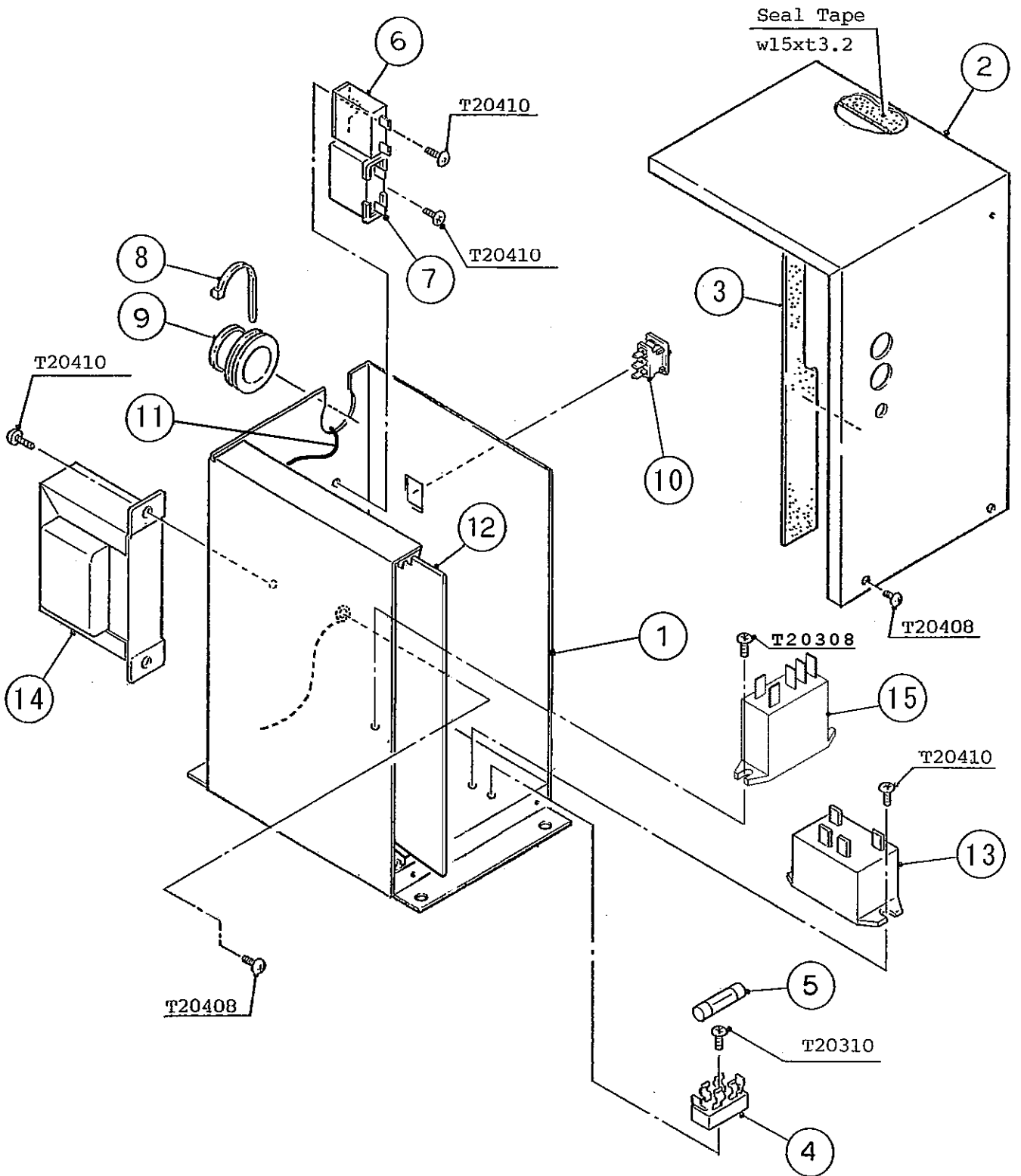

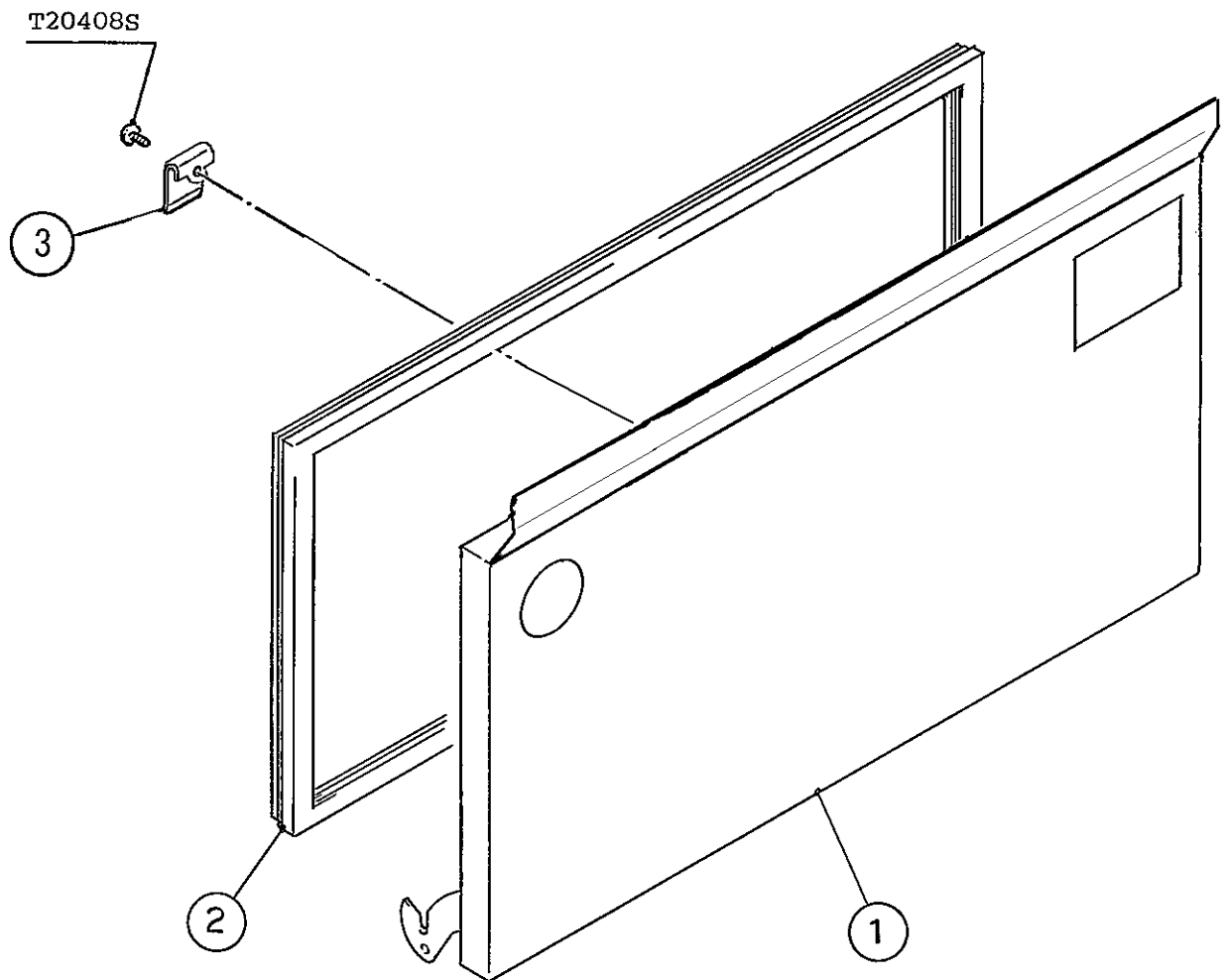

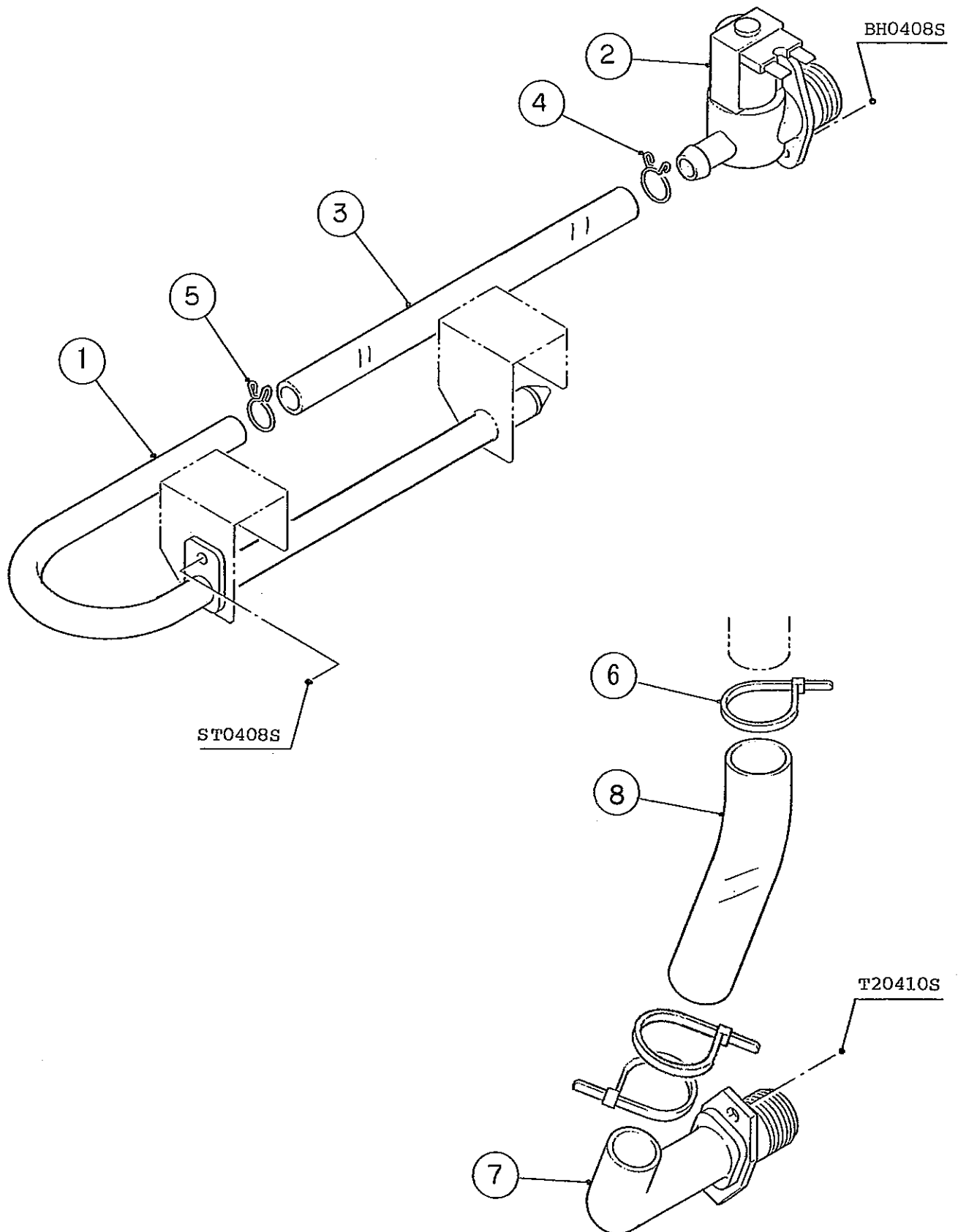

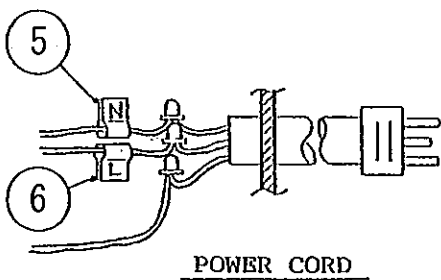
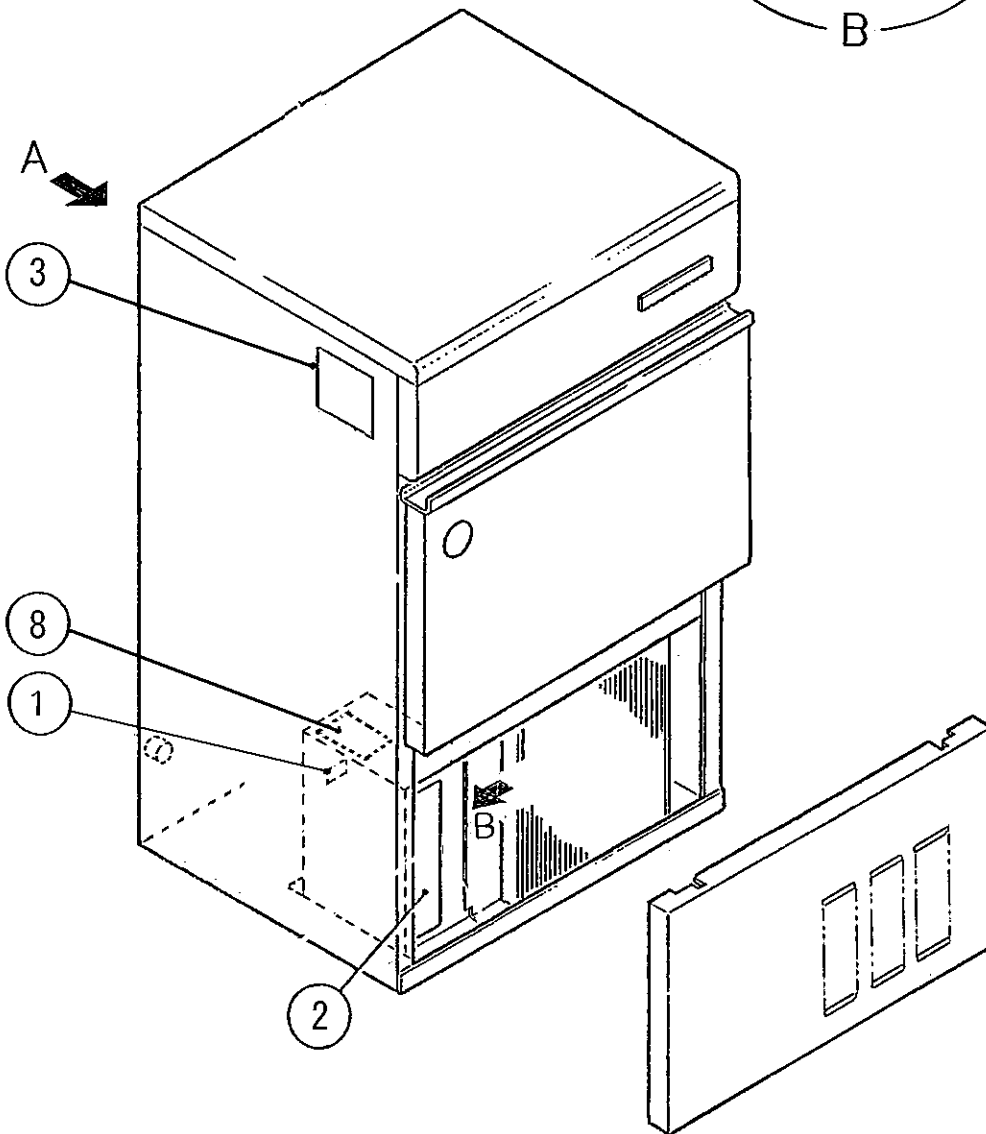
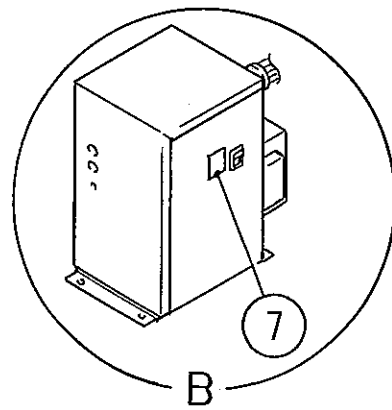
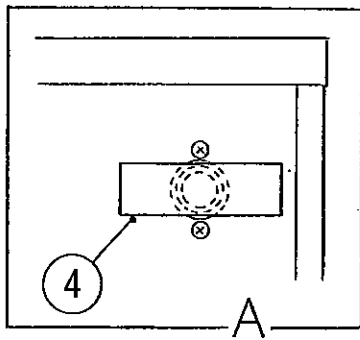

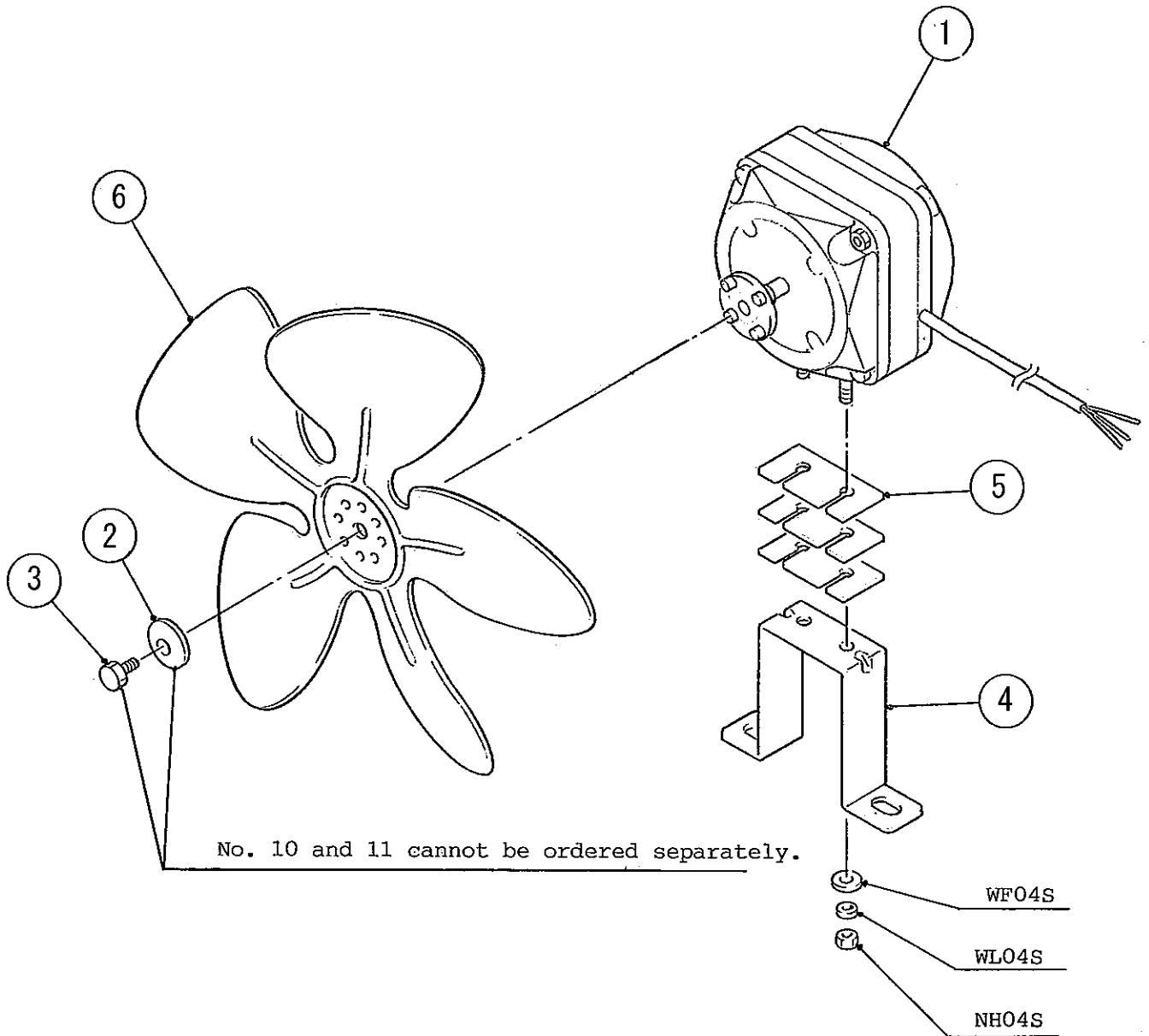

(S-0942)

IM-65LE-Q

J. BIN CONTROL SWITCH ASSY

(U-0) and later

