No. E2BB-2506

ISSUED: JAN. 26,2002

REVISED: NOV. 19,2007

SERVICE INFORMATION

: -



HOSHIZAKI MODULAR ICE MAKER

MODEL FM-251AFE(-N)

PARTS LIST (HE)

B-0	JUN.2002
C-0	DEC.2002
D-0	DEC.2003
D-1	JAN.2004
D-2	JAN.2004
E-0	JAN.2005
F-0	DEC.2005
F-1	APR.2006
G-0	JAN.2007

MATERIAL ABBREVIATIONS

ALUMINUM

AL = Aluminum

COPPER

CU = Copper

PLASTIC

ABS = Acrylonitrile -butadiene - styrene
AC = Polyacetal
EVA = Ethylene vinyl acetate
PA = Polyamide = Nylon
PC = Polycarbonate
PE = Polyethylene
PES = Polyester
PETP = Polyethylene terephthalate = Tetlon
PP = Polypropylene
PS = Polystyrene
PTFE = Polytetrafluoroethylene = Teflon
PUR = Polyurethane
PVC = Polyvinyl chloride

RUBBER

VN = Vinyl Nitrile
EPDM = EP rubber
NBR = Nitrile butadiene rubber
NR = Natural rubber
NP = Neoprene
SI.R = Silicone rubber
SY.R = Synthetic rubber
EPH = Epichlorohydrin

STEEL

GS = Galvanized steel
SS = Stainless steel
PS = Plated steel
PAS = Primed steel

AUXILIARY CODE

K-0

Designates the year. "K" indicates the year 2000. Years progress or regress in alphabetical order. "J" is 1999, "L" is 2001, "M" is 2002, and so on. The letters "I" and "O" were skipped.
Designates significant part changes within the same year. Base is 0 and this number advances for each change.

Example: P-1

"P" indicates 2004.

"1" indicates the first significant part change for 2004.

MARKS LOCATED UNDER THE AUXILIARY CODE

- = Part deleted.
x = Part deleted and replaced by "o" part.
o = New part in place of "x" part.

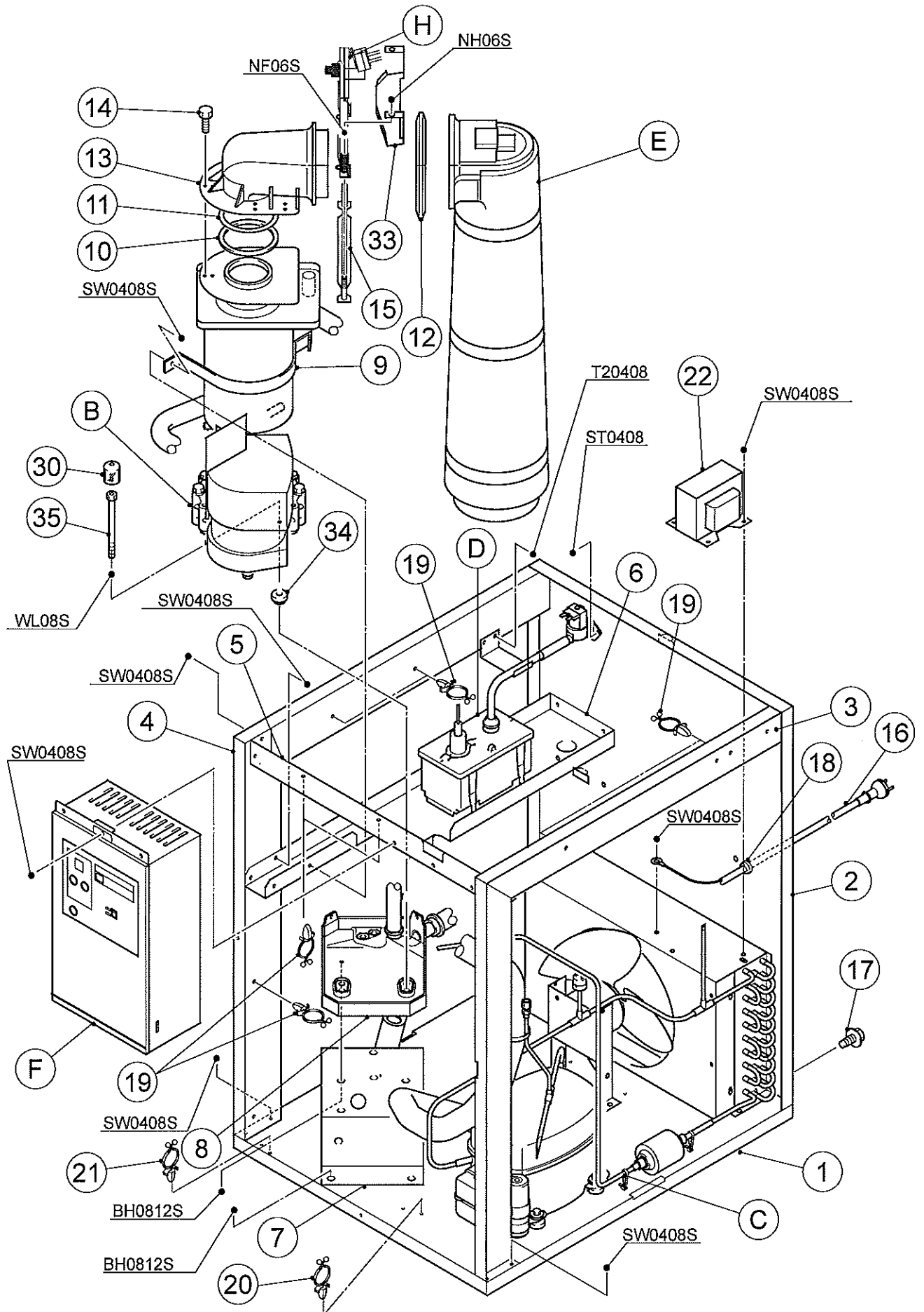

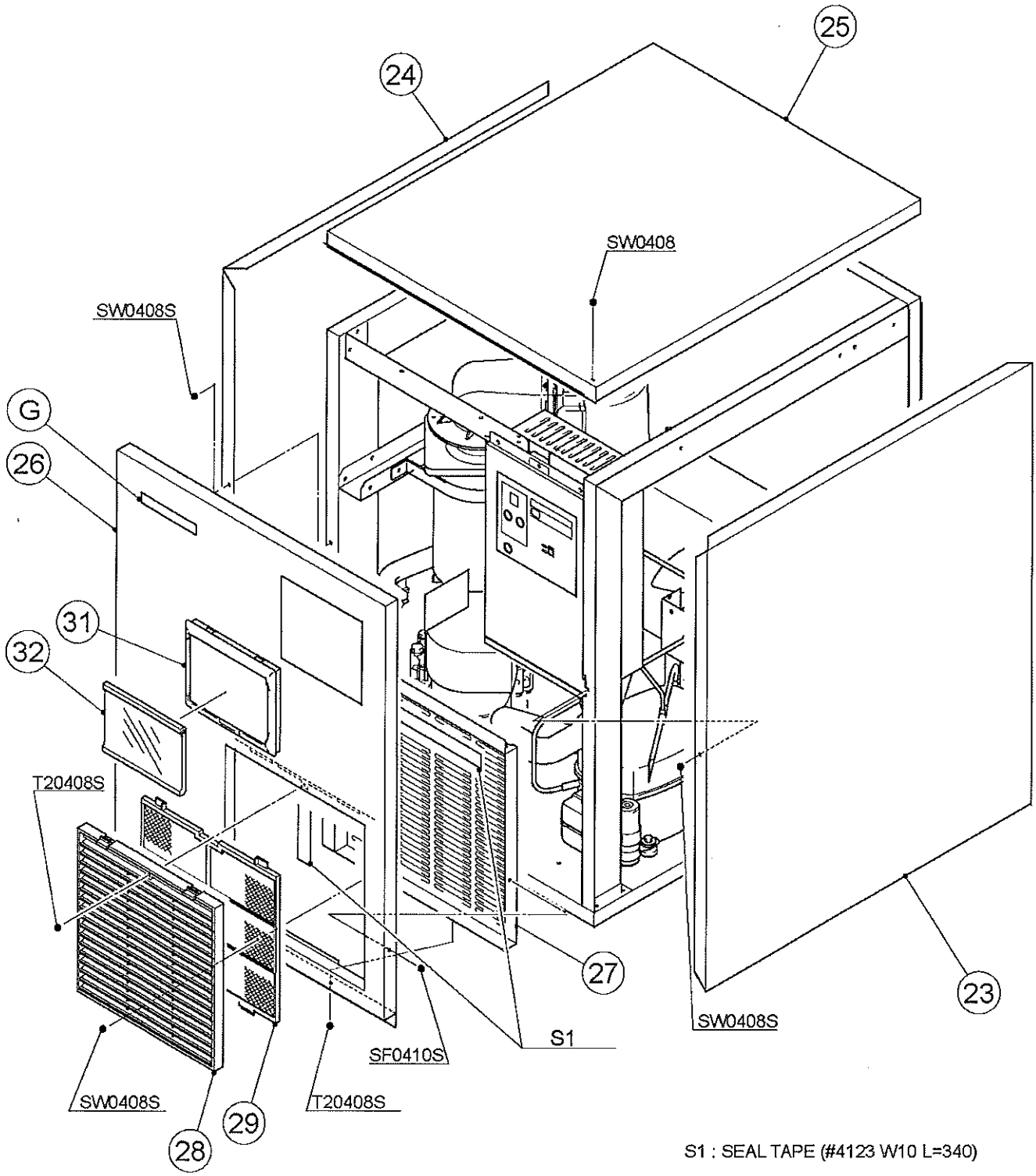

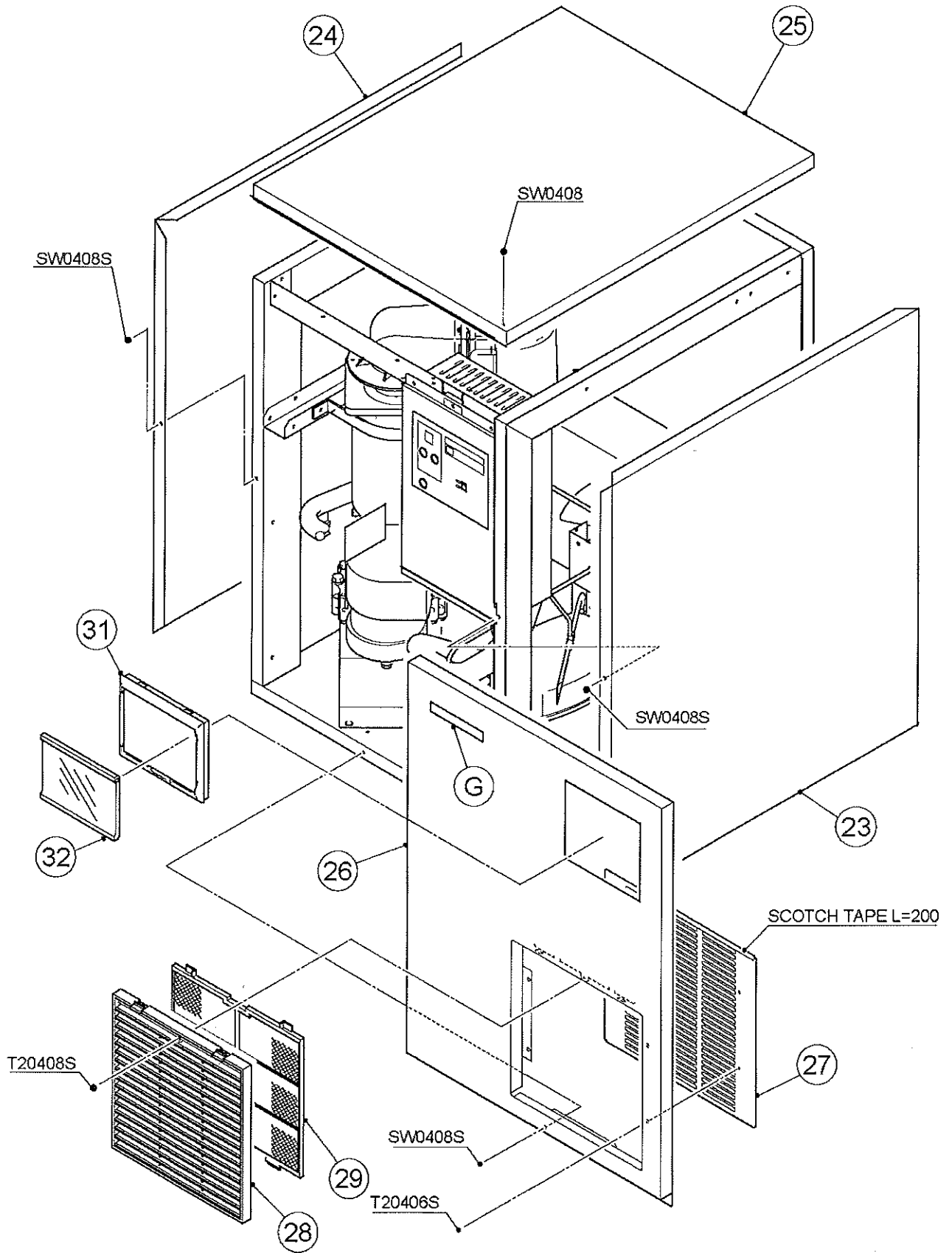

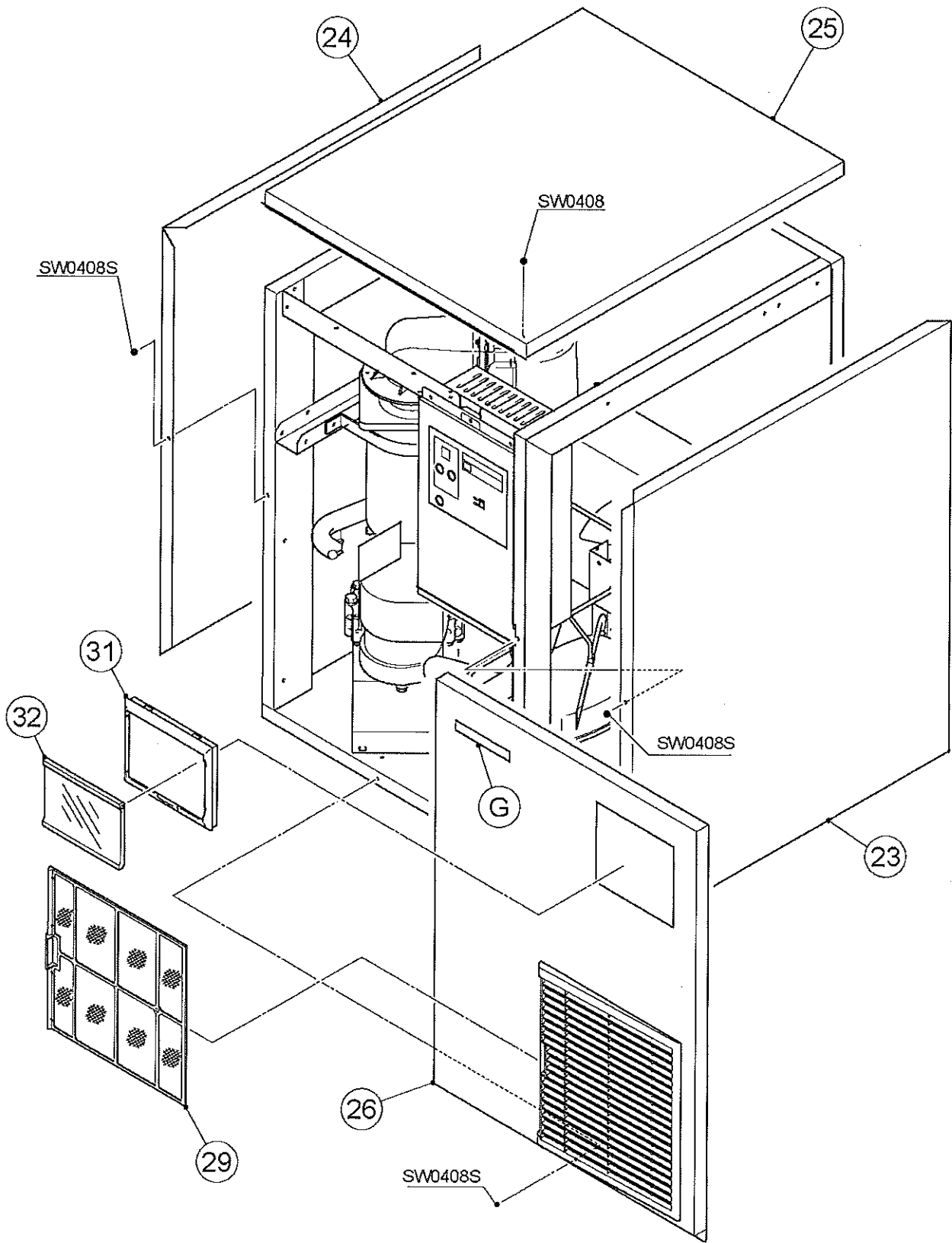

HE

MODEL: FM-251AFE(-N) TITLE: A. ICE FLAKER ASSY							
INDEX NO.	DESCRIPTION	MATERIAL OR MODEL NUMBER	PART NUMBER	REQ'D NUMBER			
				B-0	C-0	C-1 D-0	D-1 D-2
B	ICE MAKING UNIT	(FM-251AFE)	352162A01	1	1	1	-
			352162A02				1
	ICE MAKING UNIT	(FM-251AFE-N)	-	1	1	1	1
C	REFRIGERATION CIRCUIT		112553A01	1	1	-	
			112553A02			1	1
D	WATER CIRCUIT ASSY		112556A01	1	1	1	1
E	CHUTE ASSY		111514A02	1	-		
			113006A02		1	1	1
F	CONTROL BOX ASSY		237291A01	1	-		
			237291A02		1	1	-
			237291A03				1
G	LABEL LOCATION		237296A01	1	1	-	
			237296A03			1	-
			237296A04				1
H	BAND (A) ASSY	(S-9165)	348911A01	1	1	1	1
1	CHASSIS	G.S	112552G01	1	1	-	
			112552G02			1	1
2	REAR PANEL	G.S	237287-01	1	1	1	1
3	SIDE FRAME (R)	G.S	234105-01	1	1	1	1
4	SIDE FRAME (L)		234106-01	1	1	1	1
5	FRONT FRAME	G.S	347885-01	1	1	1	1
6	BRACKET - RESERVOIR	G.S	110986-01	1	1	1	1
7	BRACKET - GEAR MOTOR	G.S	352606G01	1	1	1	1
8	DRAIN PAN	ABS	323765G02	1	1	1	1
9	STRAP	G.S	459713-01	1	1	1	1
10	RING	PA	432661-02	1	1	1	1
11	"O" RING	G70	7616-G070	1	1	1	1
12	PACKING	SI	454256-01	1	1	1	1
13	SPOUT	PC	104797-01	1	1	1	1
14	THUMBSCREW	S.S, ABS	415949G04	x 5			
				o 3	3	3	3

HE

MODEL: FM-251AFE(-N) TITLE: A. ICE FLAKER ASSY							
INDEX NO.	DESCRIPTION	MATERIAL OR MODEL NUMBER	PART NUMBER	REQ'D NUMBER			
				E-0 F-0	F-1 G-0		
B	ICE MAKING UNIT	(FM-251AFE)	352162A02	1	-		
			358782A03		1		
		(FM-251AFE-N)	-	1	-		
			-		1		
C	REFRIGERATION CIRCUIT		112553A02	1	-		
			112553A03		1		
D	WATER CIRCUIT ASSY		112556A01	1	-		
			112556A02		1		
E	CHUTE ASSY		113006A02	1	1		
F	CONTROL BOX ASSY		237291A03	1	-		
			247882A01		1		
G	LABEL LOCATION		237296A04	1	-		
			237296A05		1		
H	BAND (A) ASSY	(S-9165)	348911A01	1	1		
1	CHASSIS	G.S	112552G02	1	1		
2	REAR PANEL	G.S	237287-01	1	1		
3	SIDE FRAME (R)	G.S	234105-01	-			
			115895-01	1	-		
			116720-01		1		
4	SIDE FRAME (L)		234106-01	-			
			115894-01	1	-		
			115584-01		1		
5	FRONT FRAME	G.S	347885-01	1	-		
			365628-01		1		
6	BRACKET - RESERVOIR	G.S	110986-01	1	1		
7	BRACKET - GEAR MOTOR	G.S	352606G01	1	-		
			347887G03		1		
8	DRAIN PAN	ABS	323765G02	1	1		
9	STRAP	G.S	459713-01	1	1		
10	RING	PA	432661-02	1	1		
11	"O" RING	G70	7616-G070	1	1		
12	PACKING	SI	454256-01	1	1		
13	SPOUT	PC	104797-01	1	1		
14	THUMBSCREW	S.S, ABS	415949G04	3	3		

HE

MODEL: FM-251AFE(-N) TITLE: A. ICE FLAKER ASSY							
INDEX NO.	DESCRIPTION	MATERIAL OR MODEL NUMBER	PART NUMBER	REQ'D NUMBER			
				B-0	C-0	C-1 D-0	D-1 D-2
15	BAND (B)	S.S	459995G01	1	1	1	1
16	POWER SUPPLY CORD	(CONTINENTAL) GTCE-3	452263-01	1	1	1	1
		(UK) GTBS-3	4X3521G01	1	1	1	1
17	SCREW	SUS 5x12	454353-01	2	2	2	2
18	BUSHING	CEE-SR6P10	448949-01	1	1	1	1
19	CLAMP	NO. 249	427902-03	9	9	9	9
20	CLAMP	No. 1873	427902-06	1	1	1	1
21	CLAMP	NO. 1F55	427902-07	3	3	3	3
22	TRANSFORMER	PK12-17708	434570-01	1	1	1	1
23	SIDE PANEL (R)	S.S	234109G01	1	1	1	1
24	SIDE PANEL (L)	S.S	234110G01	1	1	1	1
25	TOP PANEL	S.S	234189-01	1	1	1	1
26	FRONT PANEL	S.S	110987-01	1	-		
			113007-01		1	1	1
27	SUPPORTER		234112-01	1	-		
			238563-01		1	1	1
28	LOUVER (A)		103121-05	1	1	1	1
29	AIR FILTER (A)		208283G04	1	1	1	1
30	VINYL CAP	SH-108	451272-01	3	3	3	3
31	WINDOW FRAME		232648-01	1	1	1	1
32	WINDOW PANEL		232649-03	1	1	1	1
33	DRIP GUIDE		350725-01	1	1	1	1
34	SEAL WASHER		458299-01	1	1	1	1
35	HEX. SOCKET HEAD CAP SCREW		461285-01	1	1	1	1

HE

MODEL: FM-251AFE(-N) TITLE: A. ICE FLAKER ASSY							
INDEX NO.	DESCRIPTION	MATERIAL OR MODEL NUMBER	PART NUMBER	REQ'D NUMBER			
				E-0 F-0	F-1 G-0		
15	BAND (B)	S.S	459995G01	1	1		
16	POWER SUPPLY CORD	(CONTINENTAL) GTCE-3	452263-01	1	1		
		(UK) GTBS-3	4X3521G01	1	1		
17	SCREW	SUS 5x12	454353-01	2	2		
18	BUSHING	CEE-SR6P10	448949-01	1	1		
19	CLAMP	NO. 249	427902-03	9	9		
20	CLAMP	No. 1873	427902-06	1	1		
21	CLAMP	NO. 1F55	427902-07	3	3		
22	TRANSFORMER	PK12-17708	434570-01	1	-		
		40300E	469405-01		1		
23	SIDE PANEL (R)	S.S	234109G01	1	1		
24	SIDE PANEL (L)	S.S	234110G01	1	1		
25	TOP PANEL	S.S	234189-01	1	1		
26	FRONT PANEL	S.S	113007-01	-			
			246452G01	1	1		
27	SUPPORTER		238563-01	-			
28	LOUVER (A)		103121-05	-			
29	AIR FILTER (A)		208283G04	-			
			2A2062G01	1	1		
30	VINYL CAP	SH-108	451272-01	3	3		
31	WINDOW FRAME		232648-01	1	1		
32	WINDOW PANEL		232649-03	1	1		
33	DRIP GUIDE		350725-01	1	1		
34	SEAL WASHER		458299-01	1	1		
35	HEX. SOCKET HEAD CAP SCREW		461285-01	1	1		

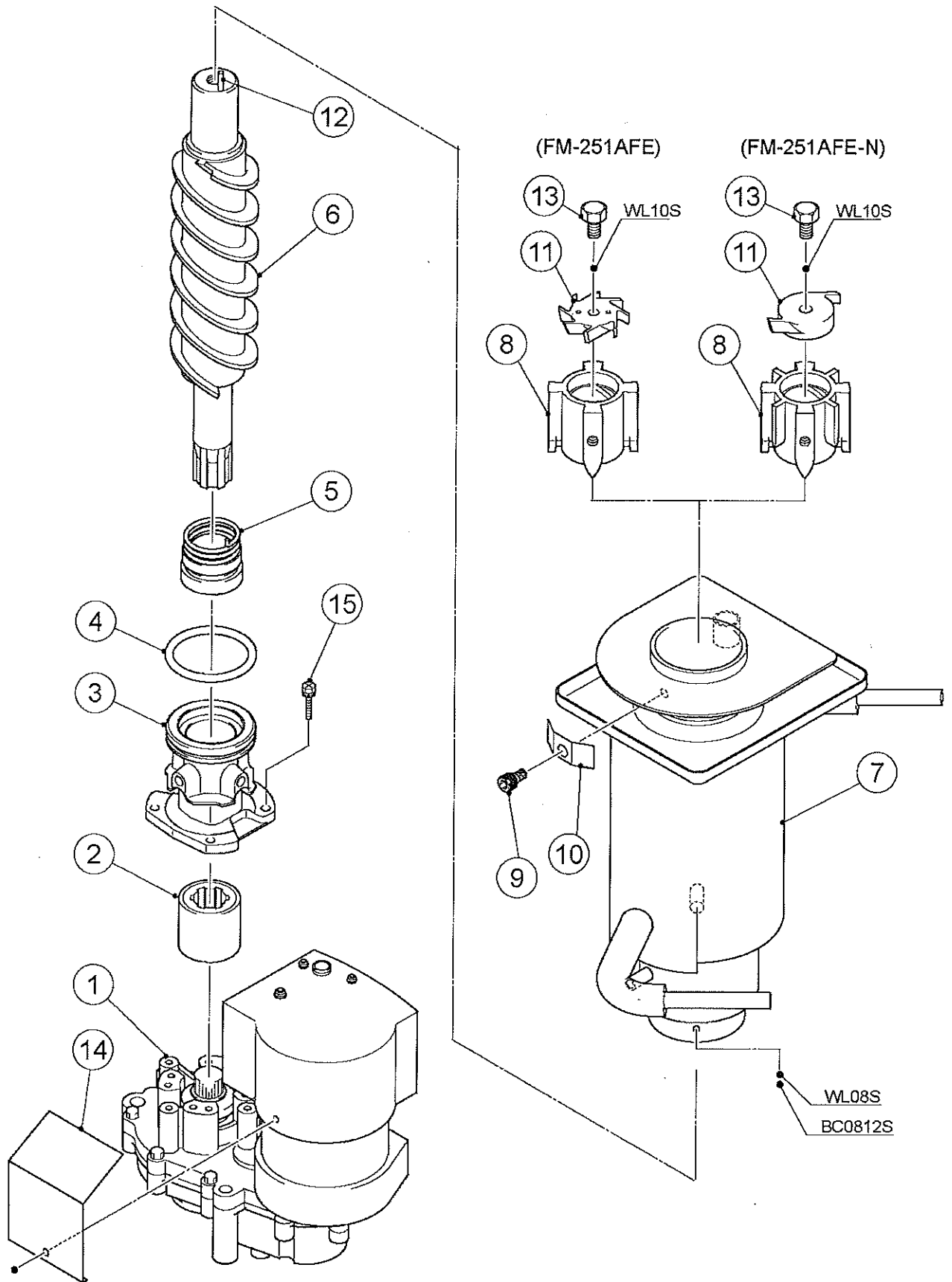

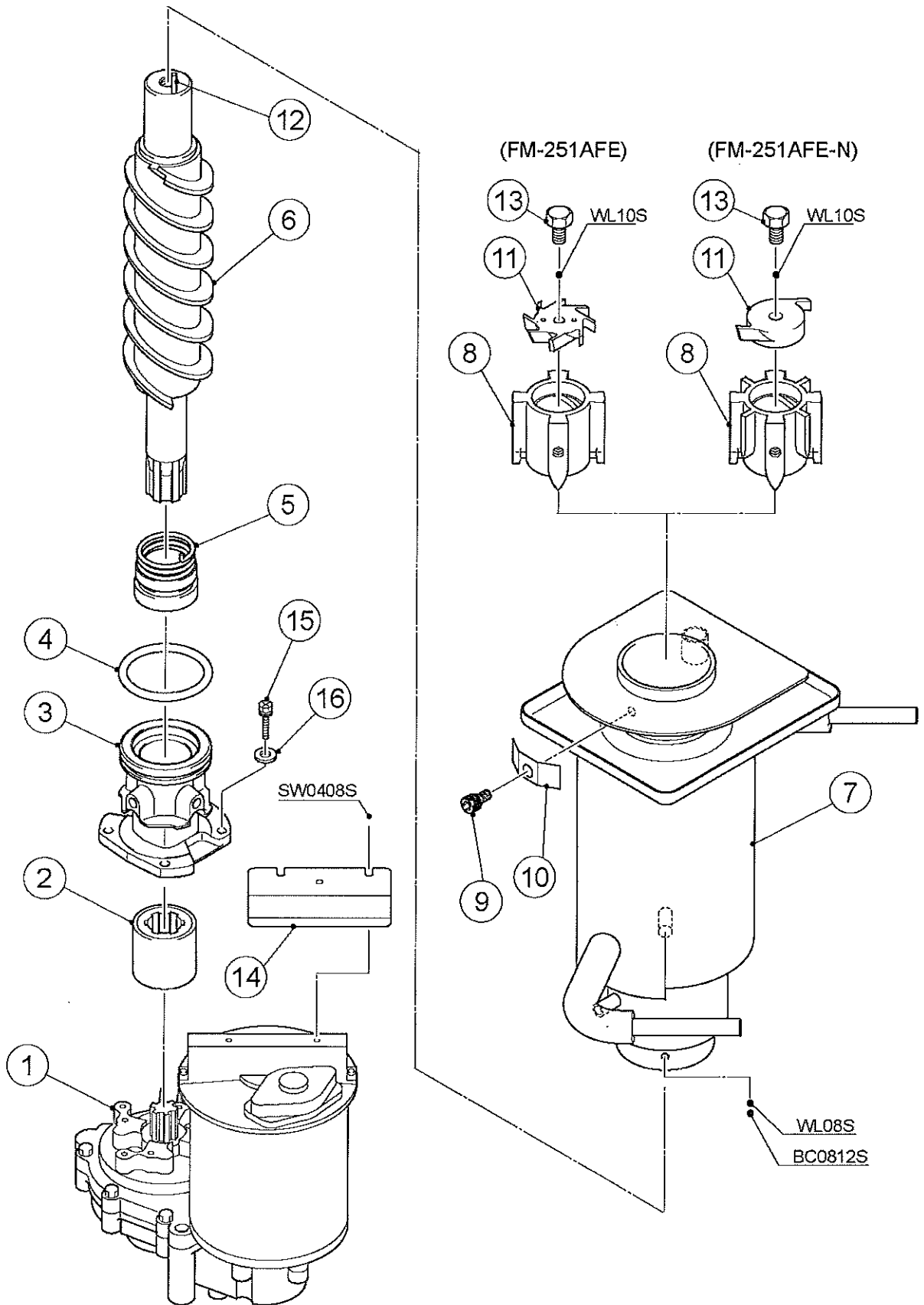

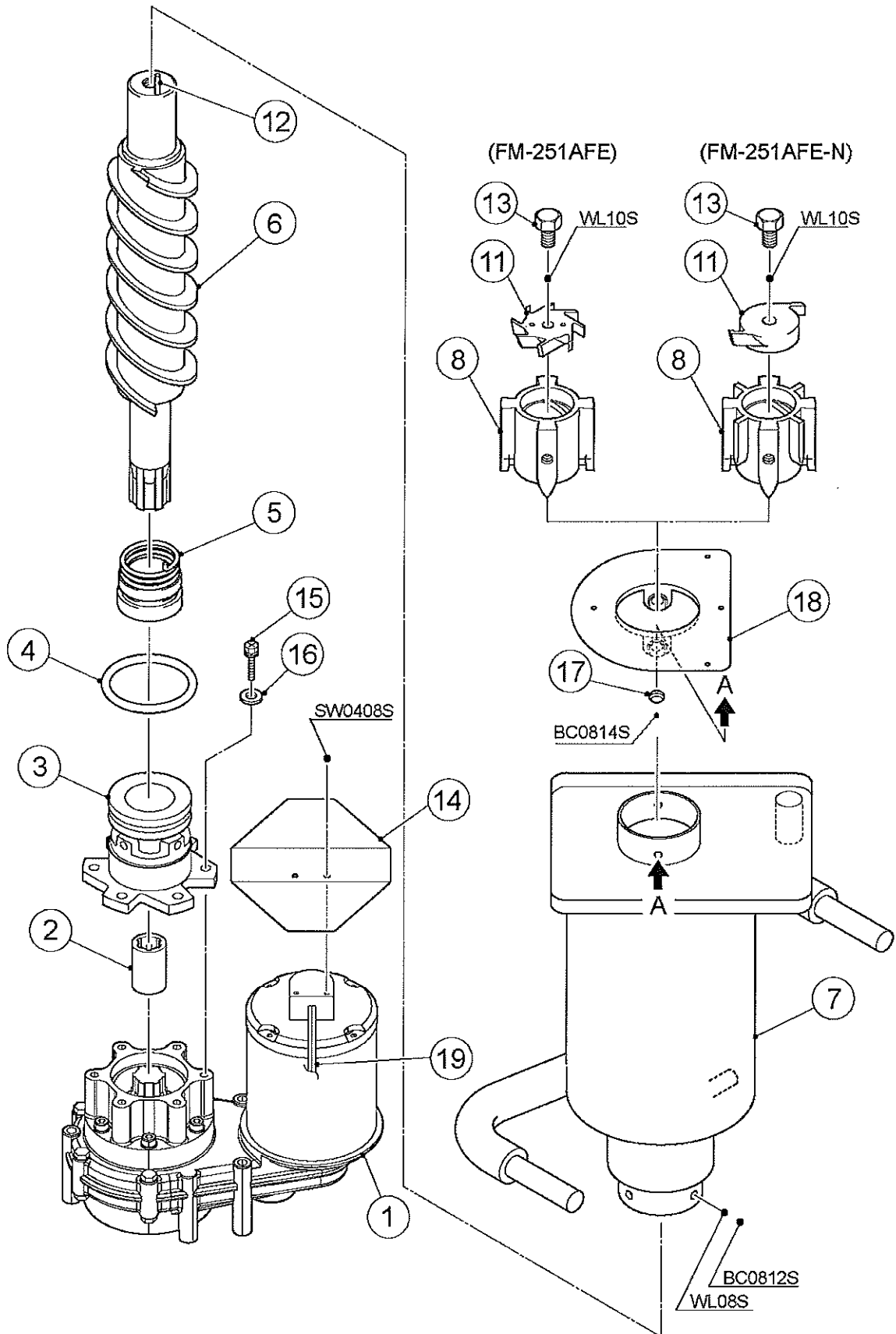

HE

MODEL: FM-251AFE(-N)		TITLE: B. ICE MAKING UNIT					
INDEX NO.	DESCRIPTION	MATERIAL OR MODEL NUMBER	PART NUMBER	REQ'D NUMBER			
				B-0	C-0	C-1 D-0	D-1 D-2
1	GEAR MOTOR	TC-1149, 80W	450455-01	1	1	1	-
		MGZ-4U 100W	446689-02				1
2	COUPLING - SPLINE	S.S	418316-01	1	1	1	1
3	HOUSING		214938G01	1	1	1	1
4	"O" RING	G65	7616-G065	1	1	1	1
5	MECHANICAL SEAL	HK9A-MN	432492-01	1	1	1	1
6	AUGER	S.S	230989G01	1	1	1	1
7	EVAPORATOR		228167G02	x 1			
			228167G06	o 1	1	1	1
8	EXTRUDING HEAD / 70F	S.S (FM-251AFE)	327097G02	1	1	1	1
	EXTRUDING HEAD / 70N	S.S (FM-251AFE-N)	216531G02	1	1	1	1
9	SOCKET HEAD CAP SCREW	S.S, M8 x 14	429121-01	4	4	4	4
10	WASHER	S.S	427184-01	4	4	4	4
11	CUTTER	S.S (FM-251AFE-N)	327145-01	1	1	1	1
		S.S (FM-251AFE)	317071-02	1	1	1	1
12	DOWEL PIN	S.S, m6A4x16	713S-0416	1	1	1	1
13	SCREW -M10	SUS 10x30	458101-01	1	1	1	1
14	COVER - GEAR MOTOR	G.S	455713-01	x 1			
			462191-01	o 1	1	1	-
			331785-02				1
15	BOLT	S.S	458660-01	4	4	4	4

HE

MODEL: FM-251AFE(-N)				TITLE: B. ICE MAKING UNIT			
INDEX NO.	DESCRIPTION	MATERIAL OR MODEL NUMBER	PART NUMBER	REQ'D NUMBER			
				E-0 F-0	F-1 G-0		
1	GEAR MOTOR	MGZ-4U 100W	446689-02	1	-		
		MGZ-3200U-150E 200W	466223-01		1		
2	COUPLING - SPLINE	S.S	418316-01	1	-		
			414137-01		1		
3	HOUSING		214938G01	1	-		
			206657G02		1		
4	"O" RING	G65	7616-G065	1	1		
5	MECHANICAL SEAL	HK9A-MN	432492-01	1	1		
6	AUGER	S.S	230989G01	1	-		
			114119G02		1		
7	EVAPORATOR		228167G06	1	-		
			239922G02		1		
8	EXTRUDING HEAD / 70F	S.S (FM-251AFE)	327097G02	1	1		
	EXTRUDING HEAD / 70N	S.S (FM-251AFE-N)	216531G02	1	1		
9	SOCKET HEAD CAP SCREW	S.S, M8 x 14	429121-01	4	-		
10	WASHER	S.S	427184-01	4	-		
11	CUTTER	S.S (FM-251AFE-N)	327145-01	1	1		
		S.S (FM-251AFE)	317071-02	1	1		
12	DOWEL PIN	S.S, m6A4x16	713S-0416	1	1		
13	SCREW -M10	SUS 10x30	458101-01	1	1		
14	COVER - GEAR MOTOR	G.S	331785-02	1	-		
			466374-01		1		
15	BOLT	S.S	458660-01	4			
		S.S 8x25	461888-01		6		
16	W/WASHER (SW)	S.S 4x8	-		2		
17	SEAL-M8		467858-01		4		
18	FLANGE/70		352713-01		1		
19	ROTATION SENSOR	HO4053-100	459861-03		1		

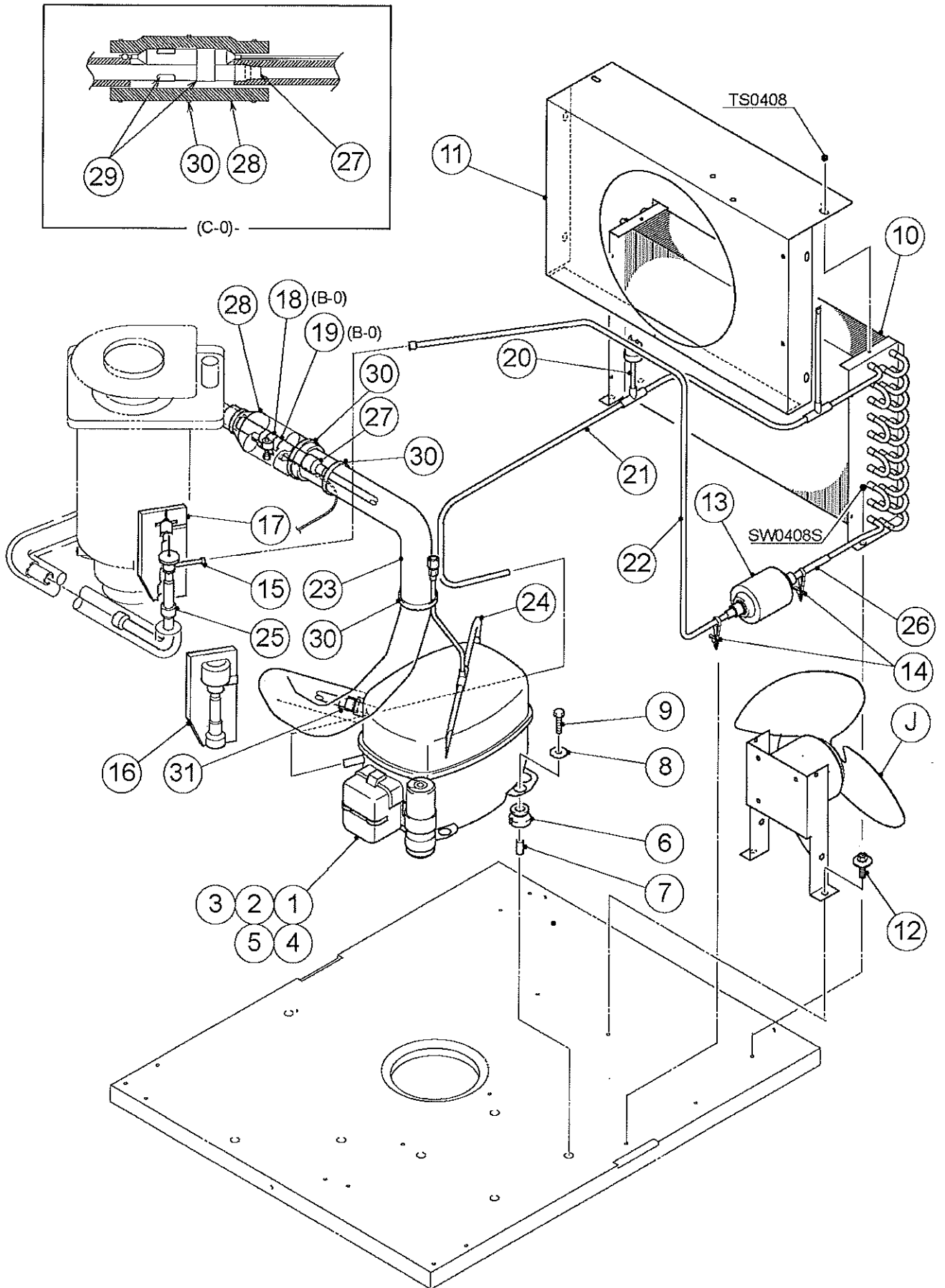

HE

MODEL: FM-251AFE(-N)		TITLE: C. REFRIGERATION CIRCUIT					
INDEX NO.	DESCRIPTION	MATERIAL OR MODEL NUMBER	PART NUMBER	REQ'D NUMBER			
				B-0	C-0	C-1 D-0	D-1 D-2
J	FAN MOTOR ASSY		338539A01	1	1	-	
			354247A01			1	1
1	COMPRESSOR	SC12DL	4A1462-01	1	1	1	1
2	CAPACITOR - STARTING	117U5017	4A1460-01	1	1	1	1
3	STARTING RELAY	117U6019	4A1455-01	1	1	1	1
4	RELIEF ASSY	103N1004	4A1454-01	1	1	1	1
5	COVER ASSY	103N2002	4A1453-01	1	1	1	1
6	RUBBER GROMMET	118-3655	4A1452-01	4	4	4	4
7	SLEEVE	112-2052	4A1451-01	4	4	4	4
8	SPACER	112-2053	4A1450-01	4	4	4	4
9	BOLT	681x1130	4A1459-01	4	4	4	4
10	CONDENSER		237299-01	1	x 1		
			238728-01		o 1	1	1
11	SHROUD	G.S	352165-01	1	1	1	1
12	SCREW	SUS, 5x12	454353-01	2	2	-	
13	DRIER	DML 032.5S	462965-01	1	1	1	1
14	PUSH MOUNT TIE	T30RSF	436156-01	2	2	2	2
15	EXPANSION VALVE	HFE-10HD-1	453008-01	1	1	1	1
16	COVER (A) - EXPANSION VALVE	PE FOAM	324313-01	1	1	1	1
17	COVER (B) - EXPANSION VALVE	PE FOAM	324313-02	1	1	1	1
18	CLAMP	S.S	443461-01	1	-		
19	HOLDER / EXP. VALVE - 1/2	S.S	3A0112-01	1	-		
20	PRESSURE SWITCH	ACB-4UB05	459864-03	1	1	1	1
21	COPPER TUBE (A) - HIGH SIDE	COPPER	352803G01	1	1	1	1
22	COPPER TUBE (B) - HIGH SIDE	COPPER	237807-01	1	1	1	1
23	COPPER TUBE (A) - LOW SIDE	COPPER	237808G01	1	1	1	1
24	COPPER TUBE (B) - LOW SIDE	COPPER	463016G01	1	1	1	1
25	COPPER TUBE (C) - LOW SIDE	COPPER	463015-01	1	1	1	1
26	COPPER TUBE (C) - HIGH SIDE	8 DIA x t 0.6 L=60	-	1	x 1		
27	REDUCING SOCKET	12.7 DIA x 9.53 DIA	421904-01	1	1	1	1

HE

MODEL: FM-251AFE(-N)				TITLE: C. REFRIGERATION CIRCUIT			
INDEX NO.	DESCRIPTION	MATERIAL OR MODEL NUMBER	PART NUMBER	REQ'D NUMBER			
				E-0 F-0	F-1 G-0		
J	FAN MOTOR ASSY		354247A01	1	1		
1	COMPRESSOR	SC12DL	4A1462-01	1	1		
2	CAPACITOR - STARTING	117U5017	4A1460-01	1	1		
3	STARTING RELAY	117U6019	4A1455-01	1	1		
4	RELIEF ASSY	103N1004	4A1454-01	1	1		
5	COVER ASSY	103N2002	4A1453-01	1	1		
6	RUBBER GROMMET	118-3655	4A1452-01	4	4		
7	SLEEVE	112-2052	4A1451-01	4	4		
8	SPACER	112-2053	4A1450-01	4	4		
9	BOLT	681x1130	4A1459-01	4	4		
10	CONDENSER		238728-01	1	1		
11	SHROUD	G.S	352165-01	1	-		
			352165-02		1		
12							
13	DRIER	DML 032.5S	462965-01	1	1		
14	PUSH MOUNT TIE	T30RSF	436156-01	2	2		
15	EXPANSION VALVE	HFE-10HD-1	453008-01	1	1		
16	COVER (A) - EXPANSION VALVE	PE FOAM	324313-01	1	1		
17	COVER (B) - EXPANSION VALVE	PE FOAM	324313-02	1	1		
18							
19							
20	PRESSURE SWITCH	ACB-4UB05	459864-03	1	1		
21	COPPER TUBE (A) - HIGH SIDE	COPPER	352803G01	1	1		
22	COPPER TUBE (B) - HIGH SIDE	COPPER	237807-01	1	1		
23	COPPER TUBE (A) - LOW SIDE	COPPER	237808G01	1	1		
24	COPPER TUBE (B) - LOW SIDE	COPPER	463016G01	1	1		
25	COPPER TUBE (C) - LOW SIDE	COPPER	463015-01	1	1		
26							
27	REDUCING SOCKET	12.7 DIA x 9.53 DIA	421904-01	1	1		

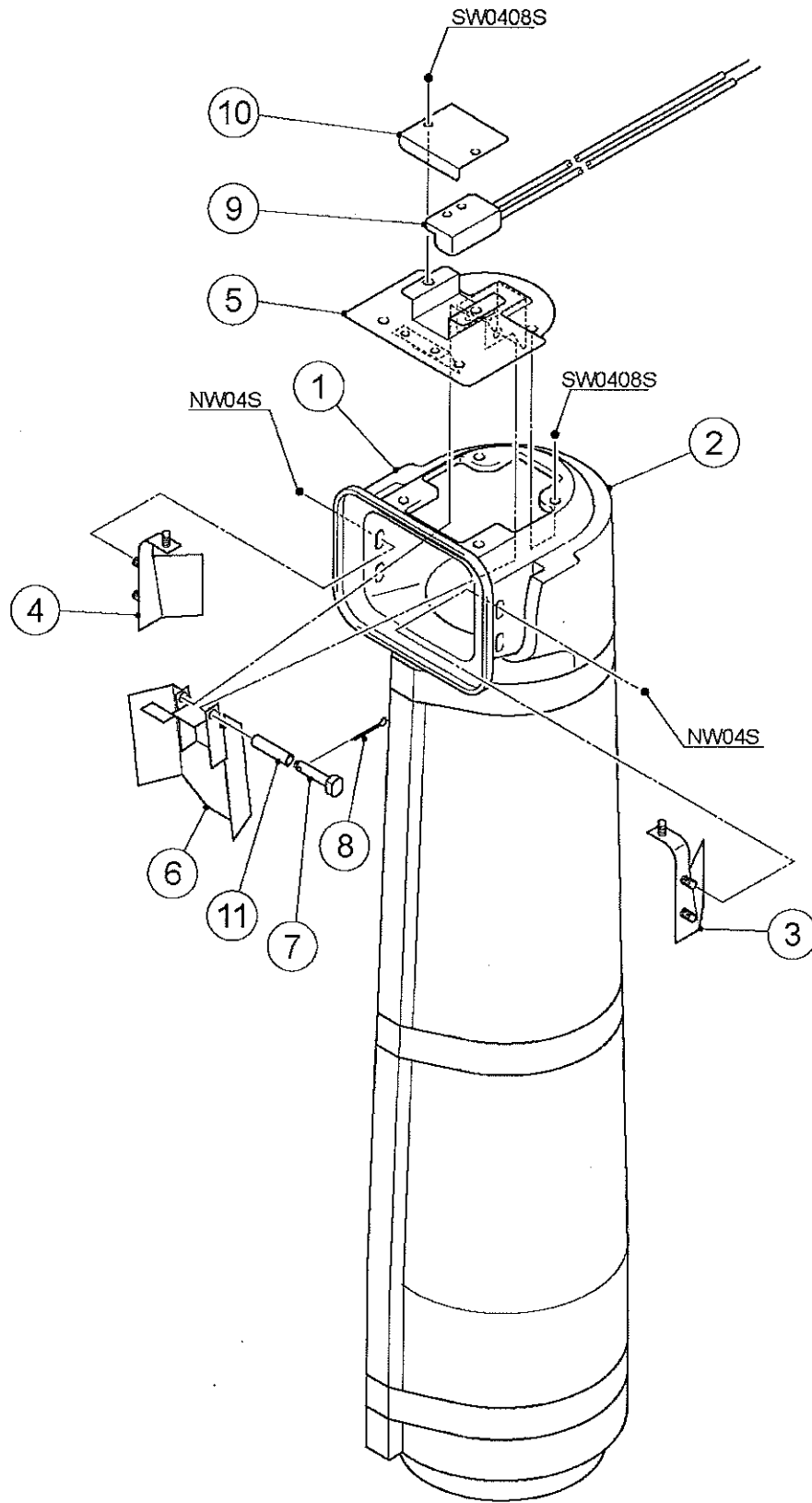

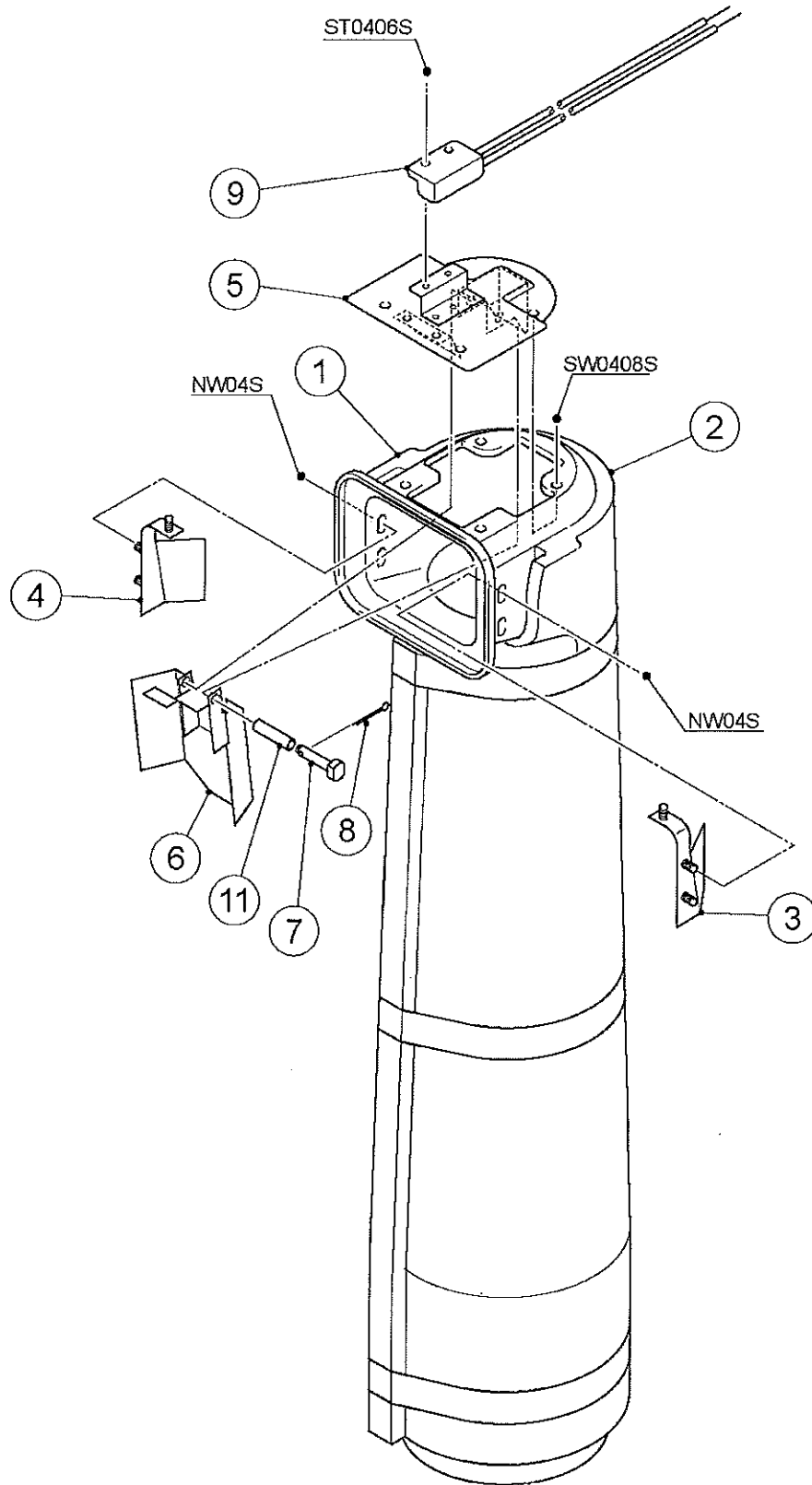

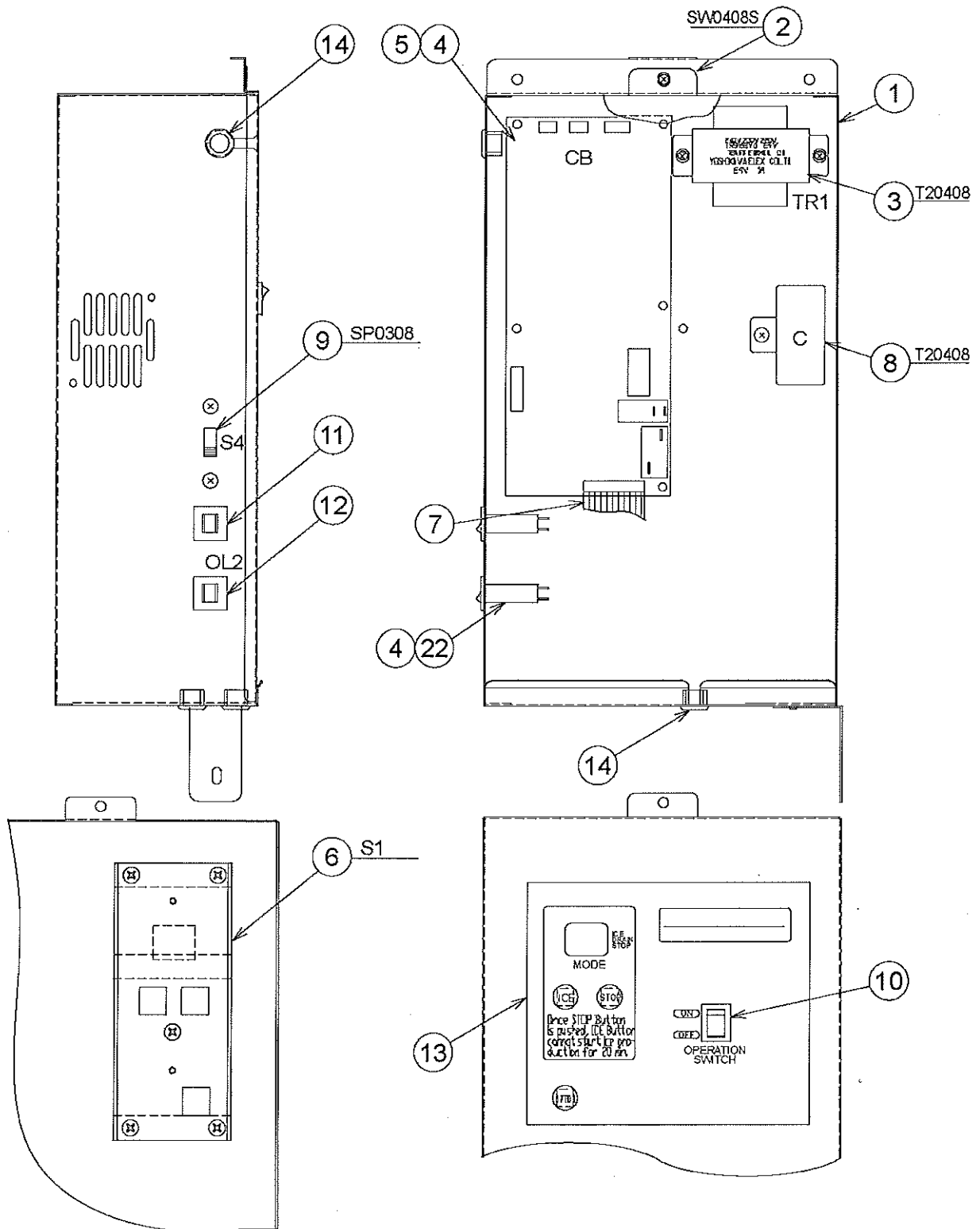

※S1: Truss Head Screw With Packing 4x8.

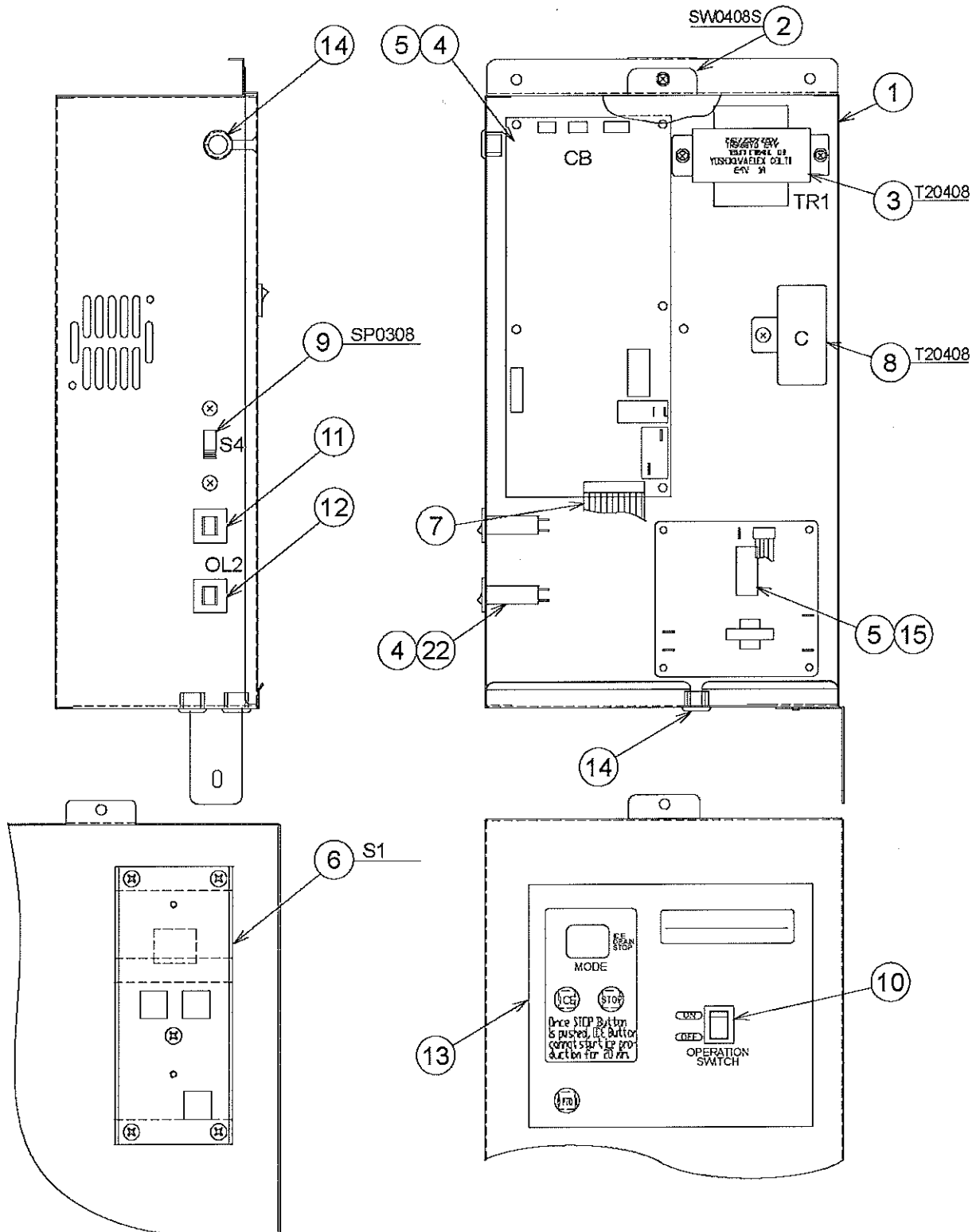

※S1: Truss Head Screw With Packing 4x8.

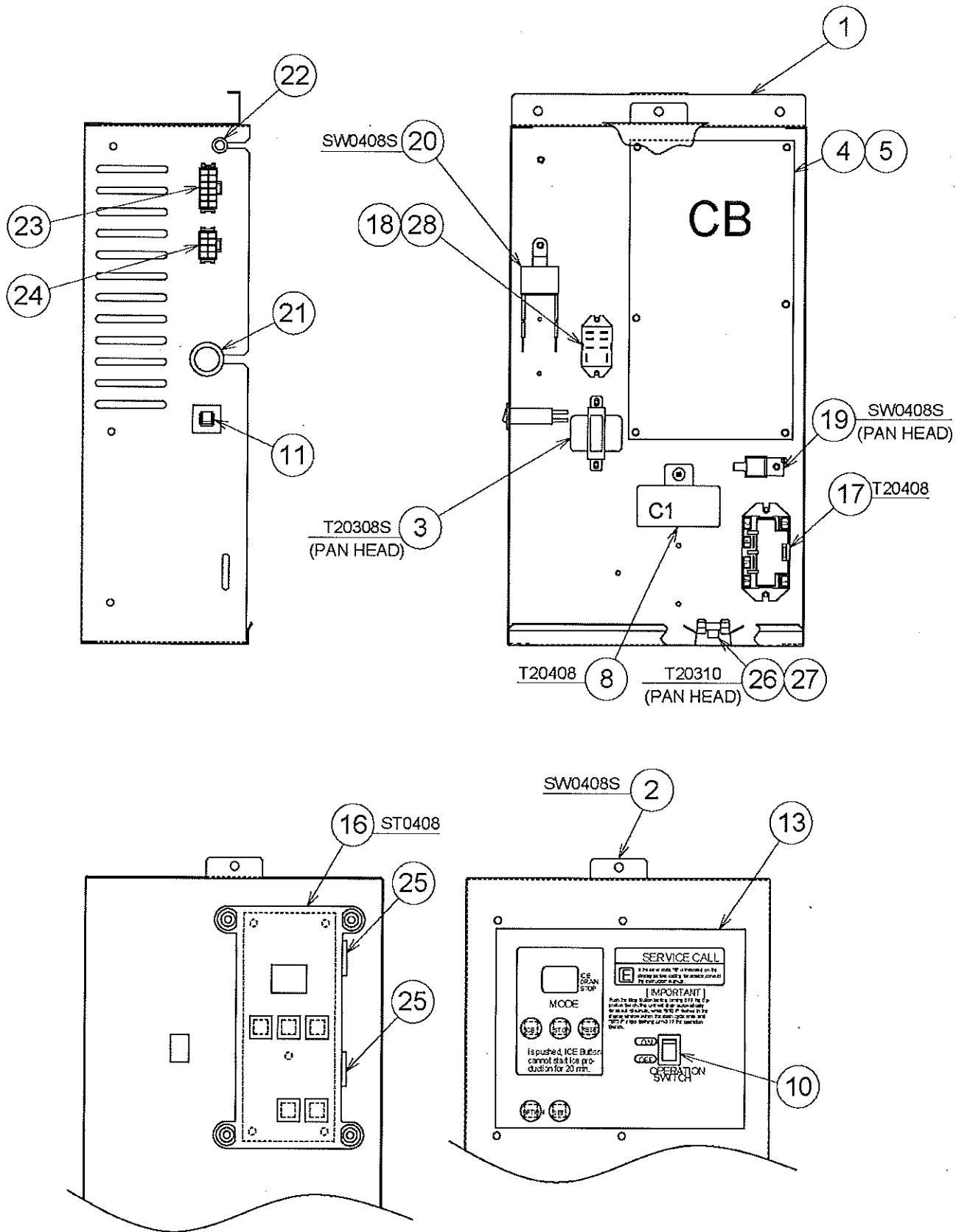

HE

MODEL: FM-251AFE(-N)		TITLE: F. CONTROL BOX ASSY					
INDEX NO.	DESCRIPTION	MATERIAL OR MODEL NUMBER	PART NUMBER	REQ'D NUMBER			
				E-0 F-0	F-1 G-0		
1	CONTROL BOX		238615G03	1	-		
	CONTROL BOX (A)		247888-01		1		
2	COVER - CONTROL BOX		347912G02	1	-		
			365634-01		1		
3	TRANSFORMER	TR9188VO	457382-01	1	-		
		HO4071-150	468601F01		1		
4	CONTROLLER BOARD	HO4055-100	461914-06	1	-		
	CONTROLLER BOARD - MAIN	HO4082-100C	468601-34		1		
5	BOARD SUPPORT	KGLS-6S	414929-01	10	-		
					6		
6	OPERATION BOARD	HO4042-200	458034-01	1	-		
7	HARNESS		458521-01	1	-		
8	CAPACITOR	ES221206PAM1	450491-01	1	-		
		CMPS45B605UWC	459704-01		1		
9	SLIDE SWITCH	FS113	435349-01	1	-		
10	ROCKER SWITCH	SL6D2	446719-01	1	-		
		SLE6A2	446719-02		1		
11	PROTECTOR	W28-XQ1A-10	440972-01	1	1		
12	PROTECTOR	W28-XQ1A-3	440972-02	1	-		
13	CONTROL LABEL		351114-01	1	-		
			358611-01		1		
14	BUSHING	OCB-625	428394-03	3	-		
15	SUB BOARD - CURRENT	HS 2003063	461144-03	1	-		
16	CONTROLLER BOARD - OPERATION	HO4073-000	465645-01		1		
17	POWER RELAY	G7L-1A-TUB	449000-01		1		
18	POWER RELAY	LY2F	406132-08		1		
19	SURGE ABSORBER		436573-02		1		
20	CAPACITOR - XY FILTER		460523-01		1		
21	BUSHING	OCB-875	428394-04		1		
22	BUSHING	OCB-375	428394-07		1		
23	HARNESS (A)		468649G01		1		
24	HARNESS (B)		469415G01		1		
25	HARNESS (D)		363728G01		1		

